

***Exigences techniques de raccordement de centrales  
au réseau de transport d'Hydro-Québec***

**Version anglaise à la suite de la décision D-2022-020**





# Technical Requirements for the Connection of Generating Stations to the Hydro-Québec Transmission System

Decision [D-20xx-xxxx](#)

[Updated: February 28, 2022](#)

a supprimé: D-2018-145

a supprimé: Effective: January 1, 2019

a mis en forme : Police :Non Gras

**a supprimé:** Technical Requirements for the Connection of Generating Stations to the Hydro-Québec Transmission System

## Table of Contents

<b>1</b>	<b>Definitions</b> .....	<b>6</b>
<b>2</b>	<b>Purpose</b> .....	<b>9</b>
<b>3</b>	<b>Application</b> .....	<b>10</b>
<b>4</b>	<b>Technical information required</b> .....	<b>12</b>
<b>5</b>	<b>General requirements</b> .....	<b>14</b>
5.1	Switchyard.....	14
5.2	Generating station connection characteristics.....	14
5.2.1	Generating station connected directly to Transmission System.....	14
5.2.2	Generating station connected through a customer facility.....	17
5.3	Bulk Power System and Main Transmission System.....	18
5.4	Design and operation of generating stations.....	18
5.4.1	Maximum loss of generation.....	18
5.4.2	Generating station islanding.....	18
5.4.3	Blackstart capability.....	18
5.4.4	Synchronizing of generating units with Transmission System.....	18
<b>6</b>	<b>Voltage- and frequency-related requirements</b> .....	<b>19</b>
6.1	Steady-state operating voltage ranges.....	19
6.2	Steady-state frequency ranges.....	19
6.3	Generating station response to disturbances on the Transmission System.....	19
6.3.1	Undervoltage response of generating station.....	19
6.3.2	Overvoltage response of generating station.....	20
6.3.3	Generating station response to frequency variations.....	21
6.4	Voltage regulation, excitation system and frequency control.....	22
6.4.1	Voltage regulation.....	22
6.4.2	Static excitation system.....	23
6.4.3	Frequency control.....	24
<b>7</b>	<b>Equipment-related requirements</b> .....	<b>25</b>
7.1	Grounding connection.....	25
7.1.1	Effectively grounded Transmission System.....	25
7.1.2	Non-effectively grounded Transmission System.....	26
7.2	General electrical characteristics of equipment.....	27
7.3	Disconnect switches.....	27
7.4	Circuit breakers.....	28
7.4.1	Tie breaker.....	28
7.5	Surge arresters on high-voltage side of switchyard.....	28
7.6	Generation equipment.....	29
7.6.1	Impedances and time constants.....	29
7.6.2	Design power factor.....	29
7.6.2.1	Synchronous generators.....	29
7.6.2.2	Other types of generating equipment.....	30
7.6.3	Harmonics.....	30
7.6.4	Inertia constant.....	30
7.7	Step-up transformers.....	30
7.7.1	Taps.....	30
7.7.2	Winding connections of step-up transformers.....	31

**a supprimé:** Decision

**a supprimé:**

7.7.3	Impedance values.....	31
7.7.4	Energizing.....	31
7.8	Voltage unbalances.....	31
7.9	Possible Transmission System voltage changes .....	32
7.10	Transmission line built by the power producer .....	32
<b>8</b>	<b>Protection system requirements .....</b>	<b>33</b>
8.1	General principles .....	33
8.1.1	Selectivity of power producer facility protection systems to Transmission System disturbances.....	33
8.1.2	Automatic reclosing.....	33
8.2	Grounding connection .....	33
8.3	Circuit breakers .....	33
8.4	Protection functions related to Transmission System needs.....	34
8.4.1	Protection from faults in power producer facilities.....	34
8.4.2	Protection from faults on Transmission System .....	34
8.4.3	Voltage protection, frequency protection and remote tripping.....	34
8.4.3.1	Voltage protection .....	35
8.4.3.2	Frequency protection .....	35
8.4.3.3	Remote tripping.....	36
8.4.4	Breaker failure protection .....	36
8.4.5	Protection from other phenomena.....	37
8.5	Equipment related to Transmission System protection requirements .....	37
8.5.1	Protective and trip relays .....	37
8.5.2	Protection system settings .....	37
8.5.3	Protection system power supply .....	37
8.5.4	Voltage and current transformers.....	37
8.6	Telecommunication systems for teleprotection functions .....	38
<b>9</b>	<b>Real-time operation requirements .....</b>	<b>39</b>
9.1	Data required for real-time Transmission System operation .....	39
9.2	Telecommunication systems for operations functions .....	41
<b>10</b>	<b>Verification of compliance with requirements.....</b>	<b>42</b>
10.1	Verification by the Transmission Provider .....	42
10.2	Verification by the power producer.....	42
10.3	Power producer equipment test reports .....	43
<b>11</b>	<b>Requirements regarding event recorders.....</b>	<b>45</b>
<b>12</b>	<b>Complementary requirements specific to generating stations using SERMOs.....</b>	<b>46</b>
12.1	Switchyard.....	46
12.2	Response of generating station using SERMOs to disturbances on the Transmission System .....	47
12.2.1	Response of generating station using SERMOs during low voltage ride through (LVRT).....	47
12.2.1.1	Inverter blocking during undervoltage and power resumption.....	49
12.2.1.2	Successive faults during a disturbance.....	50
12.2.2	Response of a generating station using SERMOs during overvoltage.....	50
12.2.2.1	Inverter blocking during overvoltage and resumption of power .....	50
12.2.2.2	Current injection during disturbances.....	51
12.2.3	Response of generating station using SERMOs to frequency variations .....	51
12.3	Voltage regulation and power factor.....	51
12.4	Frequency control.....	54
12.4.1	Primary frequency control .....	55

**a supprimé:** Technical Requirements for the Connection of Generating Stations to the Hydro-Québec Transmission System

**a supprimé:** Decision

**a supprimé:**

**a supprimé:** Technical Requirements for the Connection of Generating Stations to the Hydro-Québec Transmission System

12.4.2 Inertial response of wind generating stations .....56

12.5 Protection systems .....57

12.5.1 Voltage protection .....57

12.5.2 Frequency protection .....58

12.6 Data required for real-time Transmission System operation .....58

12.7 Technical information to submit to the Transmission Provider to conduct its studies .....59

12.8 Management of active power ramps .....59

12.9 Generating station shutdown when severe weather conditions are forecast .....59

12.10 Stabilizer .....59

12.11 Limiting active power .....59

12.12 Headroom .....60

12.13 Switchyard step-up transformers .....60

12.14 Continuous injection of reverse-sequence current .....60

12.15 Harmonics .....60

**List of mandatory reference documents ..... 61**

**List of Appendices**

Appendix A Technical information required by the Transmission Provider to conduct its studies .....62

Appendix B Information required by the Transmission Provider for modeling of generating stations using SERMOs with EMTP software .....68

Appendix C Information to be included in the power producer facility protection study .....71

Appendix D General Reference Electrical Characteristics (“CEGR”) – Static excitation system for salient-pole and round-rotor generators .....73

Appendix E General Reference Electrical Characteristics (“CEGR”) – Delta-omega multiband stabilizer .....76

Appendix F Requirements regarding verification and validation of power producer models and facilities .....85

**List of Figures**

Figure 1: *Generating station* directly connected to *Transmission System* (high-voltage side of switchyard)..... 15

Figure 2: *Generating station* directly connected to *Transmission System* (low-voltage side of switchyard) ..... 16

Figure 3: *Generating station* connected through a *customer facility*..... 17

Figure 4: Position of certain power producer devices relative to the telecommunications junction point.....38

Figure 5: Switchyard for a *generating station* using *SERMOs* .....46

Figure 6: Low voltage ride through during which the *generating station* using *SERMOs* must remain in service following a *disturbance*.....49

Figure 7: Reactive power available on high-voltage side of switchyard vs. positive-sequence voltage in normal operation .....52

**List of Tables**

Table 1: Technical information required when requesting a connection..... 12

Table 2: Minimum durations during which the *generating station* must remain in service without *generating unit tripping* when undervoltage occurs .....20

**a supprimé:** Decision

**a supprimé:**

[Technical Requirements for the Connection of Generating Stations to the Hydro-Québec Transmission System](#)

Table 3: Minimum durations during which the <i>generating station</i> must remain in service when overvoltage occurs.....	21
Table 4: Minimum durations during which the <i>generating station</i> must remain in service when frequency variation occurs .....	22
Table 5: Standard insulation and short-circuit levels for Hydro-Québec <i>Transmission System</i> equipment.....	27
Table 6: Data required by the <i>Transmission Provider</i> for the telecontrol center (TC) and System Control Center (SCC) <sup>1,2</sup> .....	39
Table 7: Maximum intervals between period checks of underfrequency trip relays for 20 MW or more <i>generating units</i> .....	43
Table 8: Minimum durations during which a <i>generating station</i> using <i>SERMOs</i> must remain in service when undervoltage occurs .....	47
Table 9: Minimum durations during which a <i>generating station</i> using <i>SERMOs</i> must remain in service when overvoltage occurs .....	50
Table 10: Minimum durations during which a <i>generating station</i> using <i>SERMOs</i> must remain in service when frequency variations occur.....	51
Table 11: Performance parameters associated with the voltage regulation function of a <i>generating station</i> using <i>SERMOs</i> .....	54
Table 12: Performance parameters associated with the primary frequency control function of a <i>generating station</i> using <i>SERMOs</i> .....	56

**a supprimé:** Technical Requirements for the Connection of Generating Stations to the Hydro-Québec Transmission System

**a supprimé:** Decision

**a supprimé:**

**a supprimé:** Technical Requirements for the Connection of Generating Stations to the Hydro-Québec Transmission System

# 1 Definitions

Italicized terms in the text are defined below.

## ***asynchronous generator***

An asynchronous machine operating to generate electricity. It [is usually connected directly](#) to the system [\(asynchronous connection\)](#).

**a supprimé:** may be connected

**a supprimé:** directly or through a converter

## ***Bulk Power System***

The *Bulk Power System* as defined in the *Glossary of Terms and Acronyms used in Reliability Standards* and its modifications as adopted from time to time by the Régie de l'énergie.

## ***closing***

The closing of a circuit breaker by a control device, an automatic control or a protection system.

## ***customer***

An "Eligible Customer" as defined in section 1.8 of the *Hydro-Québec Open Access Transmission Tariff*, as approved from time to time by the Régie de l'énergie, including a self-generator connected, or to be connected, to the *Transmission System*, where "self-generator" refers to a *customer* that is the owner-operator of a *facility* used to fulfill its energy needs in part or full.

## ***customer facility***

The native-load *customer facility* connected, or to be connected, to the *Transmission System*.

## ***disturbance***

A *disturbance* as defined in the *Glossary of Terms and Acronyms used in Reliability Standards* and its modifications as adopted from time to time by the Régie de l'énergie.

## ***energy source connected through inverters (SERMO)***

[Any primary energy or storage system source \(such as wind energy, solar irradiation or energy stored in a battery\) capable of supplying active power and using DC-AC converter technology to connect to the system.](#)

## ***Facilities Study***

The *Facilities Study* as defined in section 1.27 of the *Hydro-Québec Open Access Transmission Tariff*, as approved from time to time by the Régie de l'énergie.

## ***facility***

A *facility* as defined in the *Glossary of Terms and Acronyms used in Reliability Standards* and its modifications as adopted from time to time by the Régie de l'énergie.

## ***generating station***

In this document, a *generating station* means all power producer *facilities* located at a given generating site (e.g., a hydraulic, thermal, wind [or photovoltaic solar generating station, energy storage system<sup>1</sup>, etc.](#)), and also includes the *customer* substation when the *generating station* is connected through a *customer facility*.

**a supprimé:** or

<sup>1</sup> [A storage system alone is considered a generating station for the purposes of these technical requirements when it is able to inject active power into the Transmission System and thus constitute a source. Depending on its use, such a system, seen from the system, can also be a load.](#)

**a supprimé:** Decision

**a supprimé:**



[Technical Requirements for the Connection of Generating Stations to the Hydro-Québec Transmission System](#).

**a supprimé:** Technical Requirements for the Connection of Generating Stations to the Hydro-Québec Transmission System

### **generating unit**

A unit that produces electricity, usually comprised of a synchronous turbine-generator combination (synchronous *generating unit*) or an asynchronous turbine-generator combination (asynchronous *generating unit*) or, in the case of *generating stations using energy sources connected through inverters (SERMOs)*, the combination formed by each individual energy source and its associated inverter.

### **Glossary of Terms and Acronyms used in Reliability Standards**

Document defining terms and acronyms applicable to reliability standards in Québec and its modifications as adopted from time to time by the Régie de l'énergie.

### **Good Utility Practice**

*Good Utility Practice* as defined in section 1.44 of the *Hydro-Québec Open Access Transmission Tariff*, as approved from time to time by the Régie de l'énergie.

### **interconnection study**

In the case of a request for the connection of a *generating station*, the *system impact study* as defined in section 1.28 of the *Hydro-Québec Open Access Transmission Tariff*, as approved from time to time by the Régie de l'énergie.

### **inverter**

A device that transforms direct current from an energy source into alternating current compatible with the electrical system. The term may also refer to a usage mode of a DC-AC converter that also features a rectifier mode to transform alternating current to direct current.

### **islanding**

The splitting of a power system into subsystems comprising both a load or equipment of the *Transmission Provider* and a source that can maintain the voltage, such as a *generating facility*. This phenomenon generally arises following a *disturbance* or a switching operation.

**a supprimé:** ies

### **Main Transmission System**

The *Main Transmission System* as defined in the *Glossary of Terms and Acronyms used in Reliability Standards* and its modifications as adopted from time to time by the Régie de l'énergie.

### **Network Upgrades**

*Network Upgrades* as defined in section 1.4 of the *Hydro-Québec Open Access Transmission Tariff*, as approved from time to time by the Régie de l'énergie.

### **reclosing**

See entry for *closing*.

### **Reliability Coordinator**

The *Reliability Coordinator* as defined in the *Glossary of Terms and Acronyms used in Reliability Standards* and its modifications as adopted from time to time by the Régie de l'énergie.

### **remote tripping**

The opening of a circuit breaker actuated at a distance by an automatic control or a protection system.

### **synchronous generator**

A synchronous machine operating to generate electricity. It is usually connected directly to the system (*synchronous connection*).

**a supprimé:** may be connected to

**a supprimé:** directly or through a converter

**a supprimé:** Decision

**a supprimé:**

**a supprimé:** Technical Requirements for the Connection of Generating Stations to the Hydro-Québec Transmission System

**system**

A *system* as defined in the *Glossary of Terms and Acronyms used in Reliability Standards* and its modifications as adopted from time to time by the Régie de l'énergie.

**Transmission Provider**

Hydro-Québec when carrying on electric power transmission activities.

**Transmission System**

The *Transmission System* as defined in section 1.49 of the *Hydro-Québec Open Access Transmission Tariff*, as approved from time to time by the Régie de l'énergie.

**tripping**

The opening of a circuit breaker by a control device, an automatic control or a protection system.

**a supprimé:** Decision

**a supprimé:**

**a supprimé:** Technical Requirements for the Connection of Generating Stations to the Hydro-Québec Transmission System

## 2 Purpose

This document sets out technical requirements for the connection of *generating stations of customers* to the Hydro-Québec *Transmission System*. The *generating stations* may be connected either directly to the *Transmission System* or through *customer facilities*.

The requirements defined herein are primarily intended to ensure efficient operation of the Hydro Québec *Transmission System* based on five principles:

- Reliability of the *Transmission System*
- Stability of the *Transmission System* and of the *generating stations* connected to it
- Maintaining service quality for customers connected to the Hydro-Québec *system*
- Protection of *Transmission Provider* equipment
- Human safety
- [Equity between power producers](#)

**a supprimé:** Decision

**a supprimé:**

**a supprimé:** Technical Requirements for the Connection of Generating Stations to the Hydro-Québec Transmission System

### 3 Application

Requirements described herein apply to *generating stations* whose installed capacity is greater or equal to 1.0 MW (unless otherwise specified).

[A generating station comprising energy sources that use AC-DC converter technologies to connect to the system is designated a generating station using SERMOs. In this document:](#)

- [this includes wind generating stations \(type III and type IV\)<sup>2</sup>, photovoltaic solar generating stations, energy storage systems and any form of hybrid design that combines at least one variable generation source and one storage system;](#)
- [this excludes generating stations connected by means of a dedicated direct current transmission link.](#)

[The required technical information set out in chapter 4 applies to all generating stations. Requirements set out in chapters 5 to 11 apply to all generating stations, where relevant to the generation technology, except where there is a reference to a requirement set out in another chapter.](#)

[Requirements specific to generating stations using SERMOs are set out in chapter 12.](#)

**a supprimé:** Complementary r

**a supprimé:** wind

[A generating station may include one or more items of compensation equipment allowing it to comply with the present requirements. In such cases, the compensation equipment must itself comply with applicable requirements. The compensation equipment may be connected by inverters \(e.g., STATCOM\), in which case the relevant technical requirements set out in this document, in particular in chapter 12 and appendices A and B, apply to this equipment.](#)

All requirements presented herein apply to the connection of *generating stations* to the Hydro Québec Transmission System in any of the following situations:

- *Generating station* to be connected directly to the *Transmission System*
- *Generating station* to be connected to the *Transmission System* through a *customer facility*. In this case, *Technical Requirements for the Connection of Customer Facilities to the Hydro-Québec Transmission System*<sup>3</sup> [1] also applies
- Substantial change of a *generating station* already connected to the *Transmission System*, either directly or through a *customer facility*. Requirements apply to any equipment undergoing the substantial changes in question.

In the context of the application of technical requirements for the connection of *generating stations*, a “substantial change” is any change besides normal maintenance made to an existing *generating station* to overhaul or replace outdated apparatus or equipment, or [any modification that results in a change in the services provided, or in the generating station's electrical or mechanical characteristics, particularly: installed capacity, maximum power, control and protection systems, or station services, or in changing software \(or software versions\) for facilities using power electronics, etc.](#)

**a supprimé:** such as

**a supprimé:** rated

**a supprimé:** power

<sup>2</sup> [Type III wind generators use a doubly-fed coupling, including an inverter through which part of the generated power transits. Type IV wind generators use a coupling having only an inverter through which all the generated power transits.](#)

<sup>3</sup> As approved from time to time by the Régie de l'énergie. In this document, a number in square brackets refers to the document numbered in the list of mandatory reference documents.

**a supprimé:** Decision

**a supprimé:**

[Technical Requirements for the Connection of Generating Stations to the Hydro-Québec Transmission System](#)

Some requirements presented herein apply to *generating stations* to be connected or to the substantial change of a connected *generating station* in any of the following situations:

- The connection of a *generating station* to the distribution system<sup>4</sup>, to *facilities* of a municipal system<sup>5</sup> or of the SJBR electricity cooperative<sup>5</sup>. Requirements having an impact on the *Transmission System* then apply, namely:
  - Requirements [regarding the generating station's response during frequency variations](#), as defined in section 6.3.3 or in section 12.2.3 for [generating stations using SERMOs](#)
  - Frequency control requirements, set out in section 6.4.3 or in section 12.4 for [generating stations using SERMOs](#)
  - Frequency protection requirements, set out in section 8.4.3.2 or 12.5.2 for [generating stations using SERMOs](#)
  - *Generating station remote tripping* requirement set out in section 8.4.3.3
  - Requirements regarding measurement of injected [active and reactive power](#), needed by the telecontrol [centers](#) (TCs) and the System Control [Center](#) (SCC) set out in section 9.1 and 12.6 for [generating stations using SERMOs](#).

[In its electricity distribution activities](#), Hydro-Québec sets other requirements for *generating stations* connected to the distribution system. These requirements are presented in the document *Requirements for the Interconnection of Distributed Generation to the Hydro-Québec Medium-Voltage Distribution System* (E.12-01)<sup>6</sup>.

Other requirements, set by those responsible for the municipal system or the SJBR electricity cooperative, may also apply.

Given the evolving nature of standards and technologies, the uniqueness of each *generating station* connection project and possible system constraints, the *Transmission Provider* may specify further requirements based on its studies.

This document does not cover *generating stations* to be connected to a Hydro-Québec off-grid system<sup>7</sup>.

**a supprimé:** Technical Requirements for the Connection of Generating Stations to the Hydro-Québec Transmission System

**a supprimé:** governing frequency ranges and the minimum time *generating stations* must remain in service without *generating unit tripping*

**a supprimé:** specified

**a supprimé:** Table 4 of

**a supprimé:** Table 7 of

**a supprimé:** a wind

**a supprimé:** wind

**a supprimé:** wind

**a supprimé:** real and reactive power

**a supprimé:** centre

**a supprimé:** Centre

**a supprimé:** and described

**a supprimé:** Distribution

4 As defined in the *Act respecting the Régie de l'énergie*, art. 2 ([CQLR](#), chapter R-6.01).

5 Under the *Act respecting the Régie de l'énergie*, municipal power distribution systems governed by the *Act respecting municipal and private electric power systems* ([CQLR](#), chapter S-41), including the Coopérative régionale d'électricité de Saint-Jean-Baptiste-de-Rouville (SJBR electricity cooperative), which have been [customers of Hydro-Québec's electricity distribution activities](#) since May 13, 1997.

6 Reference provided for explanatory and information purposes only.

7 A power system permanently unconnected to the integrated Hydro-Québec *Transmission System* (e.g., system providing power to a community in Québec's Far North or Îles-de-la-Madeleine power system).

**a supprimé:** R.S.Q.

**a supprimé:** R.S.Q.

**a supprimé:** .

**a supprimé:** D

**a supprimé:** customers

**a supprimé:** only

**a supprimé:** ve

**a supprimé:** Decision

**a supprimé:**

**a supprimé:** Technical Requirements for the Connection of Generating Stations to the Hydro-Québec Transmission System

## 4 Technical information required

The *Transmission Provider* chooses the solution for the connection of the *generating station* to the *Transmission System* and determines what *Network Upgrades* this entails.

[Table 1](#) summarizes the technical information required from the power producer and the *Transmission Provider* when requesting the connection of any *generating station* to the *Transmission System* or in the advent of any substantial change to an already connected *generating station*. Technical information required from the power producer and Hydro-Québec to evaluate compliance with emission limits is specified in Appendix A of *Emission Limits for Disturbances on the Hydro-Québec Transmission System*<sup>8</sup>.

**a supprimé:** Table 1

**Table 1: Technical information required when requesting a connection**

Power producer	Transmission Provider
<b>1. Connection request or substantial change of already connected <i>generating station</i></b>	
<ul style="list-style-type: none"> <li>Information specified in Appendix A</li> </ul>	<ul style="list-style-type: none"> <li>Information specified in the <i>interconnection study agreement</i><sup>9</sup> provided for in <i>Hydro-Québec Open Access Transmission Tariff</i>, and that may include:                             <ul style="list-style-type: none"> <li>– Connection point of the <i>generating station</i> to the <i>Transmission System</i></li> <li>– Voltage of connection to <i>Transmission System</i></li> <li>– <i>Network Upgrades</i></li> <li>– Diagram of <i>generating station</i> connection</li> <li>– Short-circuit levels at the connection point</li> <li>– Any operating restrictions</li> <li>– Preliminary data on typical lead times and costs for <i>Network Upgrades</i></li> <li>– Automatic control and protection system requirements</li> <li>– Additional connection requirements that may apply, including impedance or time constant maximum values for <i>synchronous generators</i>, and/or impedance limits for <i>generating station</i> step-up transformers</li> <li>– Any relevant characteristics of the Hydro Québec <i>Transmission System</i> line and substation</li> </ul> </li> </ul>

**a supprimé:** For a wind *generating station*: oscillation characteristics of wind generators in the presence of mechanical or electrical *disturbances*<sup>1</sup>  
For a wind *generating station* detailed description of the strategy used by real power, reactive power, voltage and frequency control systems

<sup>8</sup> As approved from time to time by the Régie de l'énergie.

<sup>9</sup> Reference provided for explanatory and information purposes [only](#).

**a supprimé:** only

**a supprimé:** ve

**a supprimé:** Decision

**a supprimé:**

Power producer	Transmission Provider
<b>2. Facilities Study</b>	
<ul style="list-style-type: none"> <li>For a <i>generating station using SERMOs</i>: information specified in:                             <ul style="list-style-type: none"> <li>Appendix B</li> <li>section 12.15</li> </ul> </li> <li>Preliminary study of <i>generating station</i> protection systems, in accordance with Appendix C                             <ul style="list-style-type: none"> <li>Information specified in sections 1 to 3</li> <li>Control (or logic) and protection diagrams (section 4)</li> </ul> </li> <li>Specifications of disconnect switch (or visible disconnection point equipment)</li> <li>Specifications of current and voltage transformers for <i>Transmission System</i> protection systems</li> <li>For a <i>generating station using SERMOs</i>, demonstration of an effectively grounded neutral (section 7.7.1)</li> <li>If required, study of step-up transformer energizing operations (section 7.7.4)</li> </ul>	<ul style="list-style-type: none"> <li>Information required to complete design and engineering studies of power producer facilities, and that may include:                             <ul style="list-style-type: none"> <li>Estimated duration of work required on <i>Transmission System</i></li> <li>Data required to calculate rises in ground potential</li> <li>Complementary technical requirements for protection systems, automatic control systems, switchyard equipment and telecommunication links between switchyard and <i>Transmission System</i></li> <li>Report on tie line protection study</li> </ul> </li> <li>Special design requirements (EPC) for any line built by the power producer</li> </ul>
<b>3. Implementation and startup</b>	
<ul style="list-style-type: none"> <li>Final study of <i>generating station</i> protection systems, in accordance with Appendix C</li> <li>Description of equipment used to transmit real-time operating data</li> <li>Strategy for quickly removing from operation the tie breaker with a built-in system for detecting faulty internal states</li> <li>Test results demonstrating that a <i>generating station using SERMOs</i> meets the voltage and frequency requirements</li> <li>Validation test (initial verification) reports</li> </ul>	<ul style="list-style-type: none"> <li>Identification for switchyard equipment (nomenclature)</li> <li>Settings for voltage regulation system (or function)</li> <li>Settings for static excitation system with stabilizer</li> <li>Settings for speed governor (or, for a <i>generating station using SERMOs</i>, frequency regulation system)</li> <li>Settings for stabilizer of a <i>generating station using SERMOs</i></li> <li>Parameters for managing active and reactive power ramps according to the operating conditions of a <i>generating station using SERMOs</i></li> </ul>
<b>4. Post-commissioning</b>	
<ul style="list-style-type: none"> <li>Validation test (periodic verification) reports</li> </ul>	

a supprimé: Technical Requirements for the Connection of Generating Stations to the Hydro-Québec Transmission System

a supprimé: <#>Single-line diagram of its facilities

a supprimé: <#>wind

a supprimé: Location of switchyard

a supprimé: wind

a supprimé: the wind

a supprimé: wind

a supprimé: Decision

a supprimé:

a supprimé: Technical Requirements for the Connection of Generating Stations to the Hydro-Québec Transmission System

## 5 General requirements

Technical requirements described herein cover aspects specifically related to the *Transmission System*.

Additional requirements may be set based on information drawn from the characteristics of a given project and *Transmission Provider* studies for the connection of a *generating station* to the *Transmission System* (see [Table 1](#), for more information). The power producer must consult the *Transmission Provider* for more details.

a supprimé: Table 1

Power producer equipment and *facilities* must also comply with codes, standards and rules applicable in Québec, as well as *Good Utility Practice*.

### 5.1 Switchyard

The switchyard comprises the high-voltage portion of the substation and includes the step-up transformers and extends to their low-voltage terminal. The low-voltage portion is part of the *generating station*. If multiple voltage steps are required at the switchyard, they are also included, along with all components and lines connecting together the different output levels. Strictly for the purpose of applying technical requirements, if a *generating station* is connected to the *Transmission System* through a *customer facility*, the switchyard includes the *customer* substation.

The switchyard is connected to the *Transmission System* using the tie line. A *generating station* may need more than one tie line.

### 5.2 Generating station connection characteristics

#### 5.2.1 Generating station connected directly to Transmission System

[Figure 1](#), shows the most common connection for a *generating station* connected directly to the *Transmission System* on the high-voltage side of the switchyard.

a supprimé: Figure 1

a supprimé: Decision

a supprimé:



**Figure 1: Generating station directly connected to Transmission System (high-voltage side of switchyard)**

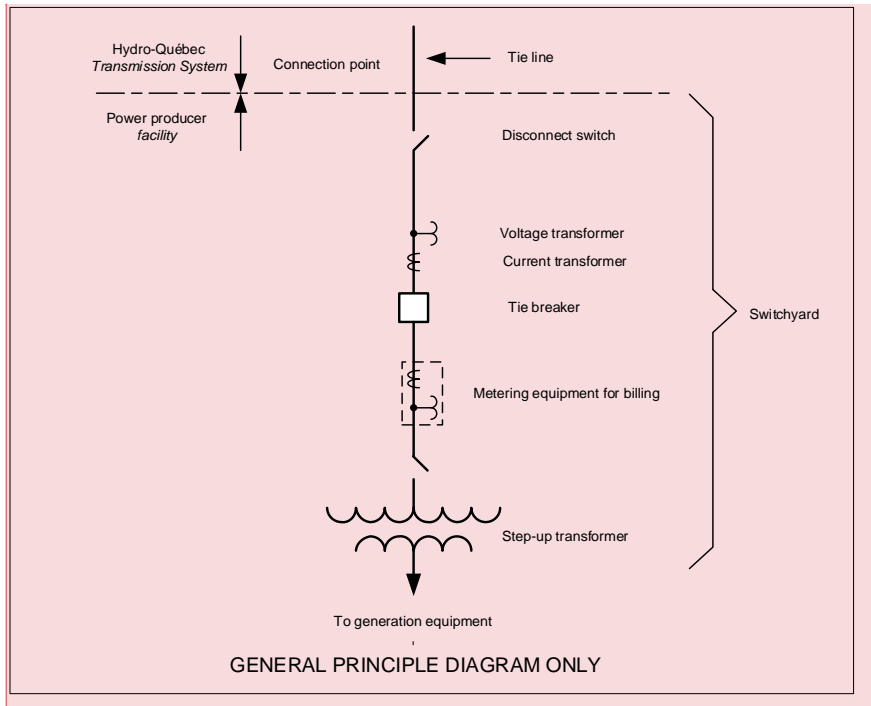

**a supprimé:** Technical Requirements for the Connection of Generating Stations to the Hydro-Québec Transmission System

**Commenté [A1]:** Figure modified by removal of Zno surge arrester.

The **connection point** is the boundary point between the *Transmission System* and the power producer facilities. In this case, the connection point is generally located on the high-voltage side of the switchyard.

The **disconnect switch** is the first visible disconnection point at each connection point; it must be located as close as possible to the connection point. This disconnect switch must be accessible at all times so the *Transmission Provider* may lock it out. It is required to isolate the *generating station* for operational purposes and to ensure the safety of personnel working on the *Transmission System*.

The **tie breaker** must be located between the step-up transformer and the disconnect switch, and as close as possible to the latter. If there are multiple step-up transformers, several breakers [positioned in series with the tie breaker](#) may be required to meet *Transmission System* needs. The tie breaker is used, in particular, to isolate the *generating station* from the *Transmission System* under fault conditions.

**Voltage and current transformers** must be located between the disconnect switch and the tie breaker, unless agreed otherwise with the *Transmission Provider*.

The **metering equipment for billing** must be located between the tie breaker and the isolating switch used to isolate the step-up transformer(s).

**a supprimé:** tie

**a supprimé:** Surge arresters to be installed by the power producer, if desired so, must also be located on the *generating station* side of the disconnect switch, unless agreed otherwise with the *Transmission Provider*.¶

**a supprimé:** Decision

**a supprimé:**

Figure 2 shows the connection of a *generating station* connected directly to the *Transmission System* on the low-voltage side of the switchyard.

a supprimé: Technical Requirements  
for the Connection of Generating Stations to the  
Hydro-Québec Transmission System

a supprimé: Figure 2

Figure 2: *Generating station* directly connected to *Transmission System*  
(low-voltage side of switchyard)

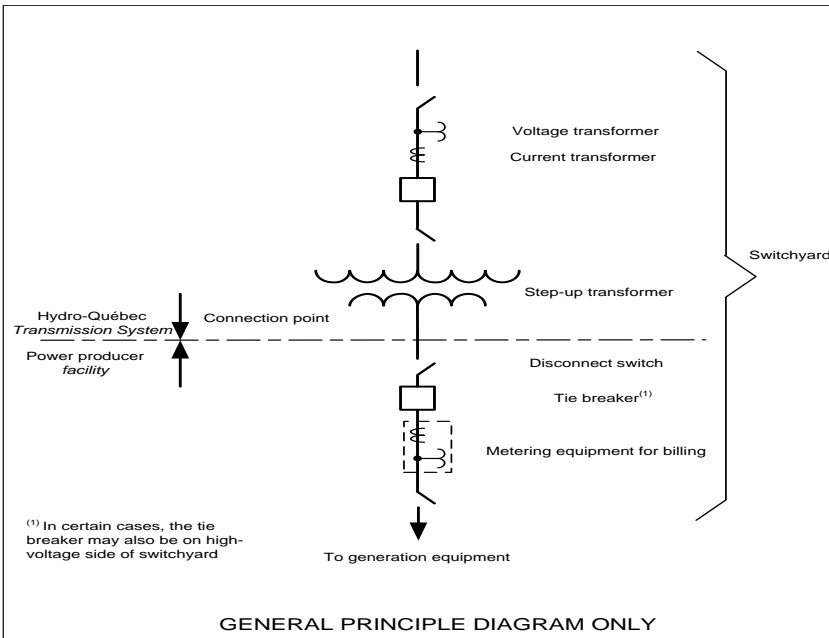

The **connection point** is the boundary point between the *Transmission System* and the power producer facilities. In this case, the connection point is generally located on the low-voltage side of the switchyard.

The **disconnect switch** is the first visible disconnection point at each connection point; it must be located as close as possible to the connection point. This disconnect switch must be accessible at all times so the *Transmission Provider* may lock it out. It is required on the low-voltage side of the switchyard to isolate the *generating station* for operational purposes and to ensure the safety of personnel working on the *Transmission System*.

The **tie breaker** may be required on the low- or high-voltage side of the step-up transformer. If there are multiple step-up transformers, several tie breakers may be required to meet *Transmission System* needs. The tie breaker is used to isolate the *generating station* from the *Transmission System* under fault conditions.

The **metering equipment for billing** must be located between the tie breaker and the related isolating switch.

a supprimé: Decision

a supprimé:

a supprimé: Technical Requirements  
for the Connection of Generating Stations to the  
Hydro-Québec Transmission System

## 5.2.2 Generating station connected through a customer facility

Figure 3 shows the most common connection for a *generating station* connected through a *customer facility*.

a supprimé: Figure 3

Figure 3: *Generating station* connected through a *customer facility*

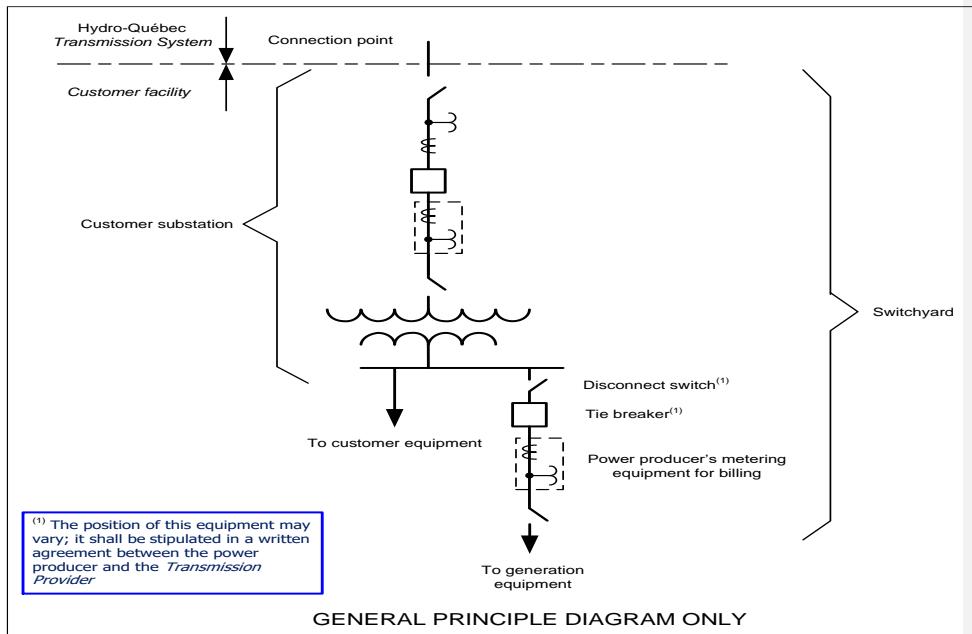

The **customer substation** must comply with *Technical Requirements for the Connection of Customer Facilities to the Hydro-Québec Transmission System* [1], as approved from time to time by the Régie de l'énergie.

The **connection point** is the boundary point between the *Transmission System* and the *customer facility*. In this case, the connection point is generally located on the high-voltage side of the *customer* substation.

The **disconnect switch** must be located as close as possible to the connection point. This disconnect switch must be accessible at all times so the *Transmission Provider* may lock it out. It is required to isolate the *generating station* for operational purposes and to ensure the safety of personnel working on the *Transmission System*.

The **tie breaker** must be located as close as possible to the disconnect switch. The tie breaker is used to isolate the *generating station* from the *Transmission System* under fault conditions.

The **metering equipment for billing** must be located between the tie breaker and the related isolating switch.

a supprimé: Decision

a supprimé:

**a supprimé:** Technical Requirements for the Connection of Generating Stations to the Hydro-Québec Transmission System

### 5.3 Bulk Power System and Main Transmission System

The *Transmission Provider* determines whether the *generating station* is part of the *Bulk Power System*. If so, it informs the power producer at the time of the *interconnection study* and submits the applicable criteria and requirements at the Régie de l'énergie for approval such that these requirements can become mandatory regarding any *generating station* being part of the *Bulk Power System*.

Furthermore, a generating *facility* that is part of the Main Transmission System, as per the definition set out by the Reliability Coordinator, is subject to reliability standards adopted by the Régie de l'énergie. The owner or the operator of the generating *facility* shall then be entered in the *Register of Entities Subject to Reliability Standards*. This Registry shall be submitted to the Régie de l'énergie for approval.

**a supprimé:** with a capacity of 50 MVA or more

**a supprimé:** , by definition,

**a supprimé:** under the supervision of

**a supprimé:** and

### 5.4 Design and operation of generating stations

#### 5.4.1 Maximum loss of generation

Any *generating station* with an installed capacity greater than 1,000 MW must be designed, built and operated so that a failure, malfunction or accidental operation of any system, device or component that is part of the power producer facilities cannot result in a loss of generation exceeding 1,000 MW.

#### 5.4.2 Generating station islanding

Unless otherwise agreed with the *Transmission Provider*, the *generating station* must not supply in islanded mode native-load Hydro-Québec customers normally connected to the Hydro-Québec system. The power producer may, however, island on its own loads, and operate its own *facilities* in islanded mode, and then assume the risks associated with self-supply.

#### 5.4.3 Blackstart capability

The power producer may be required to equip its *generating station* with a number of *synchronous generating units* having blackstart capability to allow the *Transmission Provider* to re-energize the *Transmission System* after a total blackout.

#### 5.4.4 Synchronizing of generating units with Transmission System

The *generating station* must be equipped with a frequency synchronization system for *synchronous generators* or a speed-monitoring system for *asynchronous generators* to limit *disturbances* in the *Transmission System* during synchronizing operations on its *generating units*.

Operations to synchronize *generating units* to the *Transmission System* may have to be performed on the high-voltage side of step-up transformers. Otherwise, other mitigation measures must be taken to limit *disturbances* on the *Transmission System* when step-up transformers are energized.

**a supprimé:** Decision

**a supprimé:**

## 6 Voltage- and frequency-related requirements

### 6.1 Steady-state operating voltage ranges

The *generating station* must be designed to generate and deliver to the connection point the projected maximum active power within the prescribed voltage range of the system to which it is connected.

The steady-state operating voltage of the *Transmission System* varies depending on the nominal voltage:

- ±6% on 44-kV and 49-kV systems
- ±10% on 69-kV to 315-kV systems
- -5% to +4% on the 735-kV system

On some portions of the *Transmission System*, the steady-state operating voltage range may differ from the values above to account for the characteristics of existing equipment or specific operating constraints.

### 6.2 Steady-state frequency ranges

The *generating station* must be designed to generate and deliver to the connection point the projected maximum active power within the prescribed frequency range of the system to which it is connected.

The steady-state frequency of the system may deviate from its nominal frequency (60 Hz) by ±1%, i.e., from 59.4 to 60.6 Hz.

### 6.3 Generating station response to disturbances on the Transmission System

The *generating station* and all its equipment must remain in service without *generating unit tripping*, directly or indirectly, during and after voltage and frequency deviations that follow a disturbance, for the durations given in tables 2, 3 and 4. Generating station equipment includes generators, the various auxiliary systems, control systems and compensation equipment.

The *generating station* must also help restore the *Transmission System* to normal operating conditions (voltage and frequency) after a *disturbance*.

To ensure compliance with requirements, special equipment (e.g., static or synchronous compensators) may be added to the *generating station*.

#### 6.3.1 Undervoltage response of generating station

Note: For *generating stations using SERMOs*, requirements described in this section are superseded by those described in section 12.2.1.

The *generating station* and all its equipment must remain in service without *generating unit tripping*, when undervoltages occur following a *disturbance* for the durations given in Table 2.

**a supprimé:** Technical Requirements for the Connection of Generating Stations to the Hydro-Québec Transmission System

**a supprimé:** real

**a supprimé:** may deviate from the nominal voltage by ±6% on 44-kV and 49-kV systems, and by ±10% on 69-kV or higher systems, except for the 735-kV system where the allowed deviation from the nominal voltage ranges from -5% to 4%.

**a supprimé:** allowable

**a supprimé:** real

**a supprimé:** a

**a supprimé:** when

**a supprimé:** occur following

**a supprimé:** wind

**a supprimé:** Table 2

**a supprimé:** Decision

**a supprimé:**

**Table 2: Minimum durations during which the generating station must remain in service without generating unit tripping when undervoltage occurs**

Undervoltage (p.u.) <sup>1</sup>	Minimum duration (s)
$0.9 \leq V < 1.0$	Continuously
$V < 0.9$	30
$V < 0.85$	2.0
$V < 0.75$	1.0
$V < 0.25$	0.15

1. Positive-sequence voltage on high-voltage side of switchyard.

Various *Transmission System* faults may cause the voltage to drop below 0.75 p.u. The *generating station and all its equipment* must remain in service without *generating unit tripping*, during a fault on the *Transmission System* (including the high-voltage side of the switchyard), as long as required to restore voltage after the fault is cleared, *and then resume normal operation. This may be:*

- a three-phase fault cleared in 0.15 s
- a two-phase-to-ground fault or phase-to-phase fault cleared in 0.15 s
- a multiphase fault that becomes phase-to-ground after 0.15 s cleared in an additional 0.15 s
- a phase-to-ground fault cleared in 0.30 s
- any fault with a positive-sequence voltage on the high-voltage side of the switchyard of up to 0.25 p.u. cleared by slow protection (in up to 0.75 s)

A necessity to remain in service during longer faults or voltage dips may be agreed upon with the power producer if such a solution is more advantageous overall.

### 6.3.2 Overvoltage response of generating station

Note: For *generating stations using SERMOs*, the requirements found in this section are superseded by those described in section 12.2.2.

The *generating station and all its equipment* must remain in service without *generating unit tripping*, for the durations given in the second column of *Table 3*, when overvoltages occur following a *disturbance*.

Furthermore, some *generating stations* required to ensure the integrity of *Transmission System* equipment must remain in service without *generating unit tripping* despite overvoltages that may arise from separation and instability on part or all of the *Transmission System*. It is up to the *Transmission Provider* to determine through the *interconnection study* whether a *generating station* to be connected must help perform this function. A *generating station* subject to this requirement *and all its equipment* must remain in service without *generating unit tripping*, when overvoltages occur following a *disturbance* for the durations given in the third column of *Table 3*.

a supprimé: Technical Requirements for the Connection of Generating Stations to the Hydro-Québec Transmission System

a supprimé: Undervoltage ranges (V) and

a supprimé: m

a supprimé: a

a supprimé: following a disturbance

a supprimé: Permanently

a supprimé:  $0.85 \leq$

a supprimé:  $0.75 \leq$

a supprimé:  $0.25 \leq$

a supprimé:  $0 \leq$

a supprimé: a

a supprimé: whether it is

a supprimé: minimum phase-to-ground

a supprimé: down

a supprimé: wind

a supprimé: Table 3

a supprimé: The

a supprimé: Table 3

a supprimé: Decision

a supprimé:

Table 3: Minimum durations during which the *generating station* must remain in service when overvoltage occurs

Overvoltage (p.u.) <sup>1</sup>	Minimum duration (s)	
	Requirement for all <i>generating stations</i>	Requirement for certain <i>generating stations</i> <sup>2</sup>
$1.0 \leq V \leq 1.10$	Continuously	Continuously
$V > 1.10$	300	300
$V > 1.15$	30	30
$V > 1.20$	2.0	5.0
$V > 1.25$	0.10	2.5
$V > 1.40$	0.033	0.10
$V > 1.50$	0.033	0.033

1. Positive-sequence voltage on high-voltage side of switchyard.

2. *Generating stations* protecting the integrity of *Transmission System* equipment.

### 6.3.3 Generating station response to frequency variations

Note: For *generating stations* using *SERMOs*, the requirements found in this section are superseded by those described in section 12.2.3.

The *generating station* and all its equipment must remain in service without *generating unit tripping*, when frequency variations occur following a *disturbance* for the durations given in [Table 4](#).

The *generating station* and all its equipment must also remain in service during any system frequency variation ranging from -4 Hz/s to +4 Hz/s following a *disturbance*. The requirement extends to +10 Hz/s for *generating stations* whose operation is required to protect the integrity of *Transmission System* equipment.

Requirements regarding frequency variations also apply to a *generating station* connected to the distribution system, to *facilities* of a municipal system or of the SJBR electricity cooperative.

a supprimé: Technical Requirements for the Connection of Generating Stations to the Hydro-Québec Transmission System

a supprimé: Overvoltage ranges (V) and m

a supprimé: without *generating unit tripping* following a disturbance

a supprimé: 3

a supprimé: Permanent

a supprimé: Permanent

a supprimé:  $< V \leq 1.15$

a supprimé:  $< V \leq 1.20$

a supprimé:  $< V \leq 1.25$

a supprimé:  $< V \leq 1.40$

a supprimé: <sup>2</sup>

a supprimé:  $< V \leq 1.50$

a supprimé: <sup>2</sup>

a supprimé: <sup>2</sup>

a supprimé: Note 2. Temporary blocking is allowed, after a 0.022 s delay, for *facilities* using power electronics when the positive-sequence voltage exceeds 1.25 p.u. Normal operation must resume once the voltage drops back below 1.25 p.u....

a supprimé: 3

a supprimé: wind

a supprimé: Table 4

a supprimé: Decision

a supprimé:

**Table 4: Minimum durations during which the *generating station* must remain in service when frequency variation occurs**

Frequency (Hz)	Minimum duration
$F > 66.0$ <sup>1-2</sup>	Instantly
$F > 63.0$ <sup>1-2</sup>	5 s
$F > 61.5$ <sup>1</sup>	1.5 min
$F > 60.6$	11 min
$59.4 \leq F \leq 60.6$	<u>Continuously</u>
$F < 59.4$	11 min
$F < 58.5$	1.5 min
$F < 57.5$	10 s
$F < 57.0$	2 s
$F < 56.5$	0.35 s
$F < 55.5$	Instantly <sup>3</sup>

- Instantaneous *tripping* at a frequency  $f \geq 61.7$  Hz is allowed only for *generating stations* equipped with *asynchronous generators*, and for thermal *generating stations*.
- Instantaneous *tripping* at a frequency  $f \geq 63.5$  Hz is allowed for *generating stations* connected to the distribution system.
- The term "instantly" refers to permission to issue a *tripping order* without intentional delay, but only after measuring and calculating the frequency with sufficient reliability to be immune from phase jumps and other transient phenomena. This requires the use of efficient filtering algorithms and minimal processing time, typically between 3 and 6 cycles (50–100 ms).

a supprimé: Technical Requirements for the Connection of Generating Stations to the Hydro-Québec Transmission System

a supprimé: Frequency ranges (F) and

a supprimé: without *generating unit tripping* following a disturbance

a supprimé:  $< F \leq 61.5$

a supprimé: Permanently

a supprimé: 58.5

a supprimé:  $57.5 \leq$

a supprimé: 57.0

a supprimé:  $56.5 \leq$

a supprimé:  $55.5 \leq$

a supprimé: ,

a supprimé: and photovoltaic

## 6.4 Voltage regulation, excitation system and frequency control

### 6.4.1 Voltage regulation

Note: For *generating stations* using *SERMOs*, requirements found in this section are superseded by those described in section 12.3.

The *generating station* must help achieve steady-state, dynamic and transient voltage regulation.

Every *synchronous generator* synchronized to the *Transmission System* must be equipped with an automatic voltage regulation system. It must be able to supply or absorb, under steady-state conditions, the reactive power needed to maintain the voltage corresponding to the power factor given in section 7.6.2.1. The power producer must apply the voltage regulation system settings given by the *Transmission Provider*.

For any other kind of generating equipment, voltage regulation may be achieved using the *generating units* (if the technology permits) or equipment added to the *generating station* (e.g., static or synchronous compensators). Voltage regulation performance of the *generating station* must always be comparable to that of one having equivalent capacity equipped with *synchronous generators* synchronized with the *Transmission System*. Depending on the generation technology, the power producer must demonstrate that the reactive compensation technology used does not generate overvoltages or self-excitation, particularly during *islanding*.

a supprimé: wind

a supprimé: 7.7

a supprimé: Decision

a supprimé:



[Technical Requirements for the Connection of Generating Stations to the Hydro-Québec Transmission System](#)

A *generating station* with an installed capacity of less than 10 MW must be able to operate at a constant power factor determined by the *Transmission Provider*, so that a *generating station* whose automatic voltage regulation has been disabled, including following a *disturbance*, can be operated permanently or during a period of work. The impact on the system of the disabling of the voltage regulation on response performances of the *generating station* during undervoltages (section 6.3.1) and response during overvoltages (section 6.3.2) will then be taken into account by the *Transmission Provider*. Moreover, the *Transmission Provider* may waive the requirement for an automatic voltage regulation system, especially when the short-circuit level at the connection point is much greater than the installed capacity of the *generating station*, after completing the *interconnection study*. The *generating station* must then supply sufficient reactive power to maintain a unity power factor on the high-voltage side of the switchyard, including following a *disturbance*.

Available reactive power at the connection point must not be limited by any component of the power producer *facilities* (e.g., cables or excitation limiters).

A *generating station* having an installed capacity higher than 100 MW must be designed and built to support *Transmission System* voltage regulation commands from external sources.

#### 6.4.2 Static excitation system

Every 20 MW or higher synchronous *generating unit* installed in a *generating station* whose present or ultimate installed capacity is 100 MW or more must be equipped with a static excitation system that includes a delta-omega stabilizer. This system must meet the requirements in CEGR<sup>10</sup> reference documents *Static excitation systems for salient-pole and round-rotor generators* described in Appendix D. The stabilizer must be certified by Hydro-Québec in accordance with the requirements set in CEGR reference document *Delta-omega multiband stabilizer* described in Appendix E. The *Transmission Provider* specifies the settings to be used during project implementation, but may revise them as the system evolves.

For a *generating station* located in a major load center<sup>11</sup> or a modification of the static excitation system of a *generating station* located in a major load center, the *Transmission Provider* may allow lower ceiling voltages than those specified in CEGR mentioned above for the static excitation system applicable to the *generating station*, provided the *Transmission Provider* deems benefits or performance for the system is undiminished compared to benefits or performance provided by a static excitation system with a stabilizer and high ceiling voltages.

Similarly, for the modification of a static excitation system considered slow in a *generating station* located in a major load center, the *Transmission Provider* may allow an excitation system whose performance matches that of a system equipped with a rotating diode exciter, provided the *Transmission Provider* deems benefits or performance for the system is undiminished compared to benefits or performance provided by a static excitation system with a stabilizer.

10 Caractéristiques électriques générales de référence (CEGR) [General Reference Electrical Characteristics] (TransÉnergie et équipement).

11 Major load centers are located in the south of the province, in the region roughly delimited by borders 60 km north of the Fleuve Saint-Laurent (St. Lawrence River), 60 km west of Montréal and 60 km east of the city of Québec.

**a supprimé:** Technical Requirements for the Connection of Generating Stations to the Hydro-Québec Transmission System

**a supprimé:** In the case of

**a supprimé:** centre

**a supprimé:** such

**a supprimé:** centre

**a supprimé:** centre

**a supprimé:** of Hydro Québec

**a supprimé:** and e

**a supprimé:** centre

**a supprimé:** City

**a supprimé:** Decision

**a supprimé:**

[Technical Requirements for the Connection of Generating Stations to the Hydro-Québec Transmission System](#)

For a 20 MW or lower synchronous *generating unit* or for a *generating station* whose present or ultimate installed capacity is less than 100 MW, the *Transmission Provider* may require, based on *interconnection study* results, that the synchronous *generating unit* be equipped with a static excitation system including a stabilizer. This may arise in particular if the *generating station* is far from the existing *Transmission System* or if the *generating station* could occasionally be synchronized with a neighboring system through a tie line.

### 6.4.3 Frequency control

Note: For *generating stations using SERMOs*, requirements found in this section are superseded by those described in section 12.4.

[Any generating unit with a rated power of over 10 MW that is synchronized with the Transmission System and any generating station with an installed capacity of over 10 MW](#) must have a speed governor system with a permanent speed-droop ( $\sigma$ ) adjustable over a range of at least 0 to 5% with no frequency dead band. Asynchronous *generating units* having a rated power greater than 10 MW must be equipped with a feedback system able to fulfill similar functions. The power producer must apply the speed governor system settings given by the *Transmission Provider*.

Based on *interconnection study* results, the *Transmission Provider* may however require a speed governor system on *generating units* with a rated power below 10 MW, especially if it is foreseen that under certain circumstances the *generating station* may be islanded onto loads normally connected to the Hydro-Québec *Transmission System*. Furthermore, if the *generating station* may have to be restarted in islanded mode, it must have blackstart capability.

~~The *Transmission Provider* may require that the speed governor system be permanently disabled, including following a disturbance, to prevent unwanted islanding.~~

Requirements regarding frequency control also apply to a *generating station* connected to the distribution system, to *facilities* of a municipal system or of the SJBR electricity cooperative.

**a supprimé:** Technical Requirements for the Connection of Generating Stations to the Hydro-Québec Transmission System

**a supprimé:** wind

**a supprimé:** Each

**a supprimé:** Notwithstanding the above statement,

**a supprimé:** , for some system configurations,

**a supprimé:** temporarily

**a supprimé:** after synchronizing with the *Transmission System*, to minimize the risk of

**a supprimé:** of the *generating station* onto a native-load customer connected to the *Transmission System*

**a supprimé:** Decision

**a supprimé:**

**a supprimé:** Technical Requirements for the Connection of Generating Stations to the Hydro-Québec Transmission System

## 7 Equipment-related requirements

Following standards and industry practices, the power producer must conduct engineering studies, particularly short-circuit and insulation coordination studies, in order to adequately determine the characteristics of equipment in every *generating station* to be connected to the Hydro-Québec system. In addition to the requirements described below, rotating electrical machines must comply with IEC standard 60034-1 – *Rotating electrical machines* [2].

Generating equipment connected to the *Transmission System* must be three-phase.

### 7.1 Grounding connection

*Generating stations* must be designed to be compatible at all times with the characteristics of the *Transmission System* grounding connection.

Requirements set out in sections 7.1.1 and 7.1.2 are intended to limit any temporary overvoltage that may arise when *Transmission System* circuit breakers open first to clear a ground fault on the part of the system to which a *generating station* is connected.

#### 7.1.1 Effectively grounded Transmission System

Most *facilities* on the *Transmission System* are effectively grounded, i.e., meet the following conditions:

$$0 \leq X_0/X_1 \leq 3 \text{ and } 0 \leq R_0/X_1 \leq 1$$

Where:

- X<sub>1</sub> = positive-sequence reactance of System
- X<sub>0</sub> = zero-sequence reactance of System
- R<sub>0</sub> = zero-sequence resistance of System

The *generating station* switchyard must be effectively grounded as seen from the high-voltage side.

To satisfy this requirement, the neutral on the high-voltage windings of the step-up transformer(s) used to connect the *generating station* must be grounded. Furthermore, impedance values for the transformer(s) and winding connections must ensure the *generating station* always meets the criteria for effective grounding:

$$0 \leq X_0/X_1 \leq 3 \text{ and } 0 \leq R_0/X_1 \leq 1$$

Where:

- X<sub>1</sub> = Positive-sequence reactance of *generating station* as seen from high-voltage side of switchyard
- X<sub>0</sub> = Zero-sequence reactance of *generating station* as seen from high-voltage side of switchyard
- R<sub>0</sub> = Zero-sequence resistance of *generating station* as seen from high-voltage side of switchyard.

If a *generating station* is connected to the *Transmission System* through a *customer facility*, the above-mentioned grounding connection requirements also apply (X<sub>1</sub>, X<sub>0</sub> and R<sub>0</sub> are then evaluated for the high-voltage side of the *customer* substation). It may be necessary to use the following means to meet those requirements:

**a supprimé:** Decision

**a supprimé:**

[Technical Requirements for the Connection of Generating Stations to the Hydro-Québec Transmission System](#)

- Adding grounding transformer(s) on the high-voltage side of the *customer* substation
- Modifying the connection type of existing transformer windings in the *customer* substation

[In all cases](#), depending on the characteristics of the *Transmission System* near the connection point, it may be necessary to limit the ground fault current contribution of the *generating station* substation. Additional technical requirements may be set to achieve this, such as adding a reactor on the high-voltage side, between the neutral of each transformer and the ground, or using YN-connected transformers with an appropriate zero-sequence impedance on the high-voltage side (the winding on the low-voltage side is generally delta-connected).

[The requirements indicated above to ensure effective grounding presuppose conventional generation \(e.g., synchronous generators\) having negative-sequence component impedance equal to or lower than the positive-sequence impedance. In the presence of generating stations using SERMOs, special attention to negative-sequence component impedance or to the generating station's contribution to negative-sequence component current \( \$I\_2\$ \) during faults, islanding and other transient phenomena must be given when calculating the grounding connection in order to ensure that the neutral is effectively grounded. Depending on the technologies used and the manufacturers concerned, the negative-sequence component current contribution may be nil or very low, or may take some time to reach the correct angle and the correct amplitude. This results in a non-effectively grounded neutral, as seen from the Transmission Provider's equipment that could then be subject to unacceptable overvoltages. The control systems of the converters used in the generating station could then have to be modified to ensure the required negative-sequence component contribution to ensure an effective neutral at the generating station connection point. The Transmission Provider requires the power producer to demonstrate that an effectively-grounded neutral system has been obtained through a sufficient contribution of negative-sequence component current from a generating station using SERMOs for situations such as faults and islanding.](#)

### 7.1.2 Non-effectively grounded Transmission System

In parts of the 69-kV or lower *Transmission System*, the neutral is not effectively grounded and the zero-sequence impedance is then higher than for an effectively-grounded *Transmission System*.

A *generating station* connected to a portion of the *Transmission System* where the neutral is not effectively grounded must be designed taking that fact into account so as to avoid contributing more than 400 A to the single-phase fault current on that portion of the *Transmission System* unless the *Transmission Provider* agrees otherwise. A grounding transformer of appropriate impedance will also generally be required on the high-voltage side of the switchyard to keep the zero-sequence [component](#) impedance from becoming capacitive (due, for instance, to the capacitive effect of lines or cables on the *Transmission System* side) and causing significant overvoltages.

[As mentioned in section 7.1.1, the negative-sequence component current contribution must be considered in calculating the grounding connection for a generating station using SERMOs.](#)

a supprimé: Technical Requirements for the Connection of Generating Stations to the Hydro-Québec Transmission System

a supprimé: power

a supprimé: producer

a supprimé: Decision

a supprimé:

a supprimé: Technical Requirements for the Connection of Generating Stations to the Hydro-Québec Transmission System

## 7.2 General electrical characteristics of equipment

The electrical characteristics of equipment forming the power producer *facilities* must be compatible with those of the *Transmission System* to which the *facilities* are connected, especially regarding insulation coordination. [Table 5](#) gives current standard values for insulation and short-circuit levels on the *Transmission System*. In designing its *facilities*, the power producer must check with the *Transmission Provider* to confirm the electrical characteristics that apply to the portion of the *Transmission System* to which its *facilities* are to be connected.

a supprimé: Table 5

**Table 5: Standard insulation and short-circuit levels for Hydro-Québec Transmission System equipment**

Nominal system voltage <sup>1</sup> (kV L-L rms)	Rated voltage of equipment <sup>2</sup> (kV L-L rms)	Ground insulation level <sup>3</sup>		Standard short-circuit levels <sup>4</sup> (kA sym. rms)
		<Lightning (kV peak)	60 Hz (kV rms.)	
69	72.5	350	140	31.5
120	132	550	230	40 and 50 <sup>6</sup>
161	170	650–750 <sup>5</sup>	275–325 <sup>5</sup>	31.5 and 50 <sup>6</sup>
230	245	850–950 <sup>5</sup>	360–395 <sup>5</sup>	31.5 and 50 <sup>6</sup>
315	330	1,050–1,175 <sup>5-7</sup>	460	31.5 and 50 <sup>6</sup>

a supprimé: <sup>2</sup>

a supprimé: <sup>3</sup>

a supprimé: 145

a supprimé: <sup>4</sup>

a supprimé: <sup>4</sup>

a supprimé: <sup>5</sup>

a supprimé: <sup>4</sup>

a supprimé: <sup>4</sup>

a supprimé: <sup>5</sup>

a supprimé: <sup>4-6</sup>

a supprimé: <sup>5</sup>

1. For 44-kV, 49.2-kV, 345-kV and 735-kV systems, insulation and short-circuit levels have not been standardized and must be confirmed by the *Transmission Provider* on a case-by-case basis.

2. Rated voltage is the highest level of phase-to-phase voltage for which the equipment is intended to operate in continuous service. A higher operating voltage value may be present in the system, as indicated in the *Caractéristiques de la tension fournie par le réseau de transport d'Hydro-Québec*<sup>12</sup>.

3. Insulation levels between open contacts of disconnect switches must be higher than the ground insulation level. This requirement also applies to 330-kV circuit breakers.

4. The X/R ratio specified for these voltage levels is equivalent to 30.

5. The lower value applies to transformers and shunt reactors protected by surge arresters at their terminals, while the higher value applies broadly to all other equipment.

6. The short-circuit level depends on the specific characteristics of the *Transmission System* near the generating station connection point.

7. The switching impulse withstand voltage is 850 kV peak.

a supprimé: 3 –

a supprimé: 4 –

a supprimé: 5 –

a supprimé: to which the close to

a supprimé: is connected

a supprimé: 6 –

## 7.3 Disconnect switches

To ensure the safety of all personnel working on the *Transmission System*, each connection point in the switchyard must be equipped with a disconnect switch. This disconnect switch constitutes a visible disconnection point, accessible to the *Transmission Provider* for the purpose of isolating the *generating station* from the *Transmission System*. The disconnect switch must be located as close as possible to the connection point, and it must be possible to lock it out in the open position (blades opening upwards forming an angle greater than 90°).

a supprimé: supplied only

a supprimé: ve

a supprimé: Decision

a supprimé:

<sup>12</sup> Reference provided for explanatory and information purposes only.

**a supprimé:** Technical Requirements for the Connection of Generating Stations to the Hydro-Québec Transmission System

For motorized disconnect switches, it must be possible to disable, uncouple and lock out the control and drive mechanism. A device for cutting power to the motor (e.g., using a knife-switch) and a place for installing a padlock on the control box door must be provided. The control tube must also include a locking device equipped with a pin. Furthermore, if the emergency mechanism is a wheel, it must be possible to lock out the external selection switch, and the knife-switches must be visible through a window when the control box is closed and locked out. If the emergency mechanism is crank-operated, the knife-switches and local control selector switch must be visible through a window when the control box is closed and locked out. Openings for padlocks or locking clamps must have a diameter of 12 mm.

There may be more than one disconnect switch at any power producer *facility*. In some cases, the *Transmission Provider* may allow some device other than a disconnect switch (e.g., a rack-mounted circuit breaker) to be used as a visible disconnection point.

In all cases, the power producer must submit the equipment's specifications to the *Transmission Provider*, which will check that they comply with its safety requirements.

In no instance may a disconnect switch be coupled to a grounding switch on the *Transmission System* side, since such a configuration would automatically ground the connection point when the disconnect switch opens.

## 7.4 Circuit breakers

Circuit breakers must have adequate insulation withstand and interrupting capacity [e.g., transient recovery voltage (TRV), recovery voltage (RV), short-term withstand current, short-circuit interrupting capacity] to interrupt any kind of fault current within the power producer *facilities* or on any part of the *Transmission System* to which the *generating station* is connected. Particular care must be taken regarding insulation and out-of-phase faults to ensure that circuit breakers have the required interrupting capacity.

### 7.4.1 Tie breaker

The power producer must equip its *facilities* with one or several tie breakers. The devices must be able to perform an open-close-open (O-C-O) cycle during eight consecutive hours with no power from the *system* in the event of a prolonged power failure. [Moreover, they must be designed to be operated and manoeuvred at an ambient temperature of -50°C. Depending on the geographic area in which they are installed, the \*Transmission Provider\* could allow the use of tie breakers designed for operation at -40°C.](#)

If a tie breaker has a built-in system for detecting faulty internal states (e.g., low SF<sub>6</sub> [gas](#) density) that can force it to close or disable its normal functioning (e.g., latching up [or locking after a closing command](#)), the power producer must, when a faulty state is detected, [in addition to the mitigation measures described in section 8.3](#), remove the breaker in question from service as quickly as possible so as to avoid any damage to its *facilities* or undue *disturbances* on the *Transmission System*. The power producer must submit to the *Transmission Provider* for approval the measures it intends to take to meet this requirement.

## 7.5 Surge arresters on high-voltage side of switchyard

[If the power producer wishes to install high-voltage surge arresters, they](#) must be located on the *generating station* side of the disconnect switch, unless the *Transmission Provider* agrees otherwise, so they may be isolated from the *Transmission System* without de-energizing the *Transmission Provider's* tie line.

**a supprimé:** H

**a supprimé:** Decision

**a supprimé:**

[Technical Requirements for the Connection of Generating Stations to the Hydro-Québec Transmission System](#)

Surge arresters must be of the zinc oxide type with no spark gap and appropriately rated for *Transmission System* constraints.

## 7.6 [Generation equipment](#)

### 7.6.1 [Impedances and time constants](#)

Following the *interconnection study*, the *Transmission Provider* may impose additional requirements on certain impedance or time constant values for *synchronous generators* (e.g., maximum  $X''_{qi} / X''_{di}$ , maximum  $X'_{di}$  or  $T'_{do}$ ) to ensure *Transmission System* stability is maintained. By way of indication,  $X''_{qi} / X''_{di}$  values for *synchronous generators* currently connected to the *Transmission System* generally range from 1.0 to 1.3, while the typical value of  $X'_{di}$  is 0.3 p.u. based on equipment MVA. The typical value of time constant  $T'_{do}$  is 6.0 seconds.

### 7.6.2 [Design power factor](#)

Note: For *generating stations using SERMOs*, requirements found in this section are superseded by those described in section 12.3.

Power factors specified below set [the values](#) for the range of reactive power that the *generating station* must make available to the system under steady-state conditions<sup>13</sup>.

#### 7.6.2.1 [Synchronous generators](#)

*Synchronous generators* synchronized with the system must have a rated power factor not exceeding:

- 0.90 in over-excited mode
- 0.95 in under-excited mode.

These power factors are specified at the synchronous generator terminals.

[In addition](#), for a *generating station* with the connection point on the high-voltage side of the switchyard, the power factor in over-excited mode must also not exceed 0.95 at the connection point.

However, if the *interconnection study* shows that reactive power from the *synchronous generators* cannot be completely used on the *Transmission System*, the *Transmission Provider* may accept a rated power factor at the generator terminals, in over-excited mode, greater than 0.9 though not exceeding 0.95. For a *generating station* with the connection point on the high-voltage side of the switchyard, the power factor in over-excited mode must also not exceed 0.97 at the connection point.

<sup>13</sup> If the *generating station* is connected to the system through a *customer facility*, a metering system able to distinguish between the industrial consumption and generation parts must be installed; this will allow the real contribution of the *generating station* and its load consumption to be calculated, so as to verify compliance with power factor requirements.

**a supprimé:** Technical Requirements for the Connection of Generating Stations to the Hydro-Québec Transmission System

**a supprimé:** Synchronous and asynchronous generator voltage unbalances, impedances and time constants

**a déplacé vers le bas [1]:** Power producer facilities, particularly synchronous and asynchronous generators, must be designed to withstand, without tripping, voltage unbalances of up to 2% (negative-sequence component,  $V_2/V_1$ ) under steady-state conditions on the *Transmission System* and even greater unbalances for a limited time (e.g., a 50% voltage unbalance under fault conditions).

**a supprimé:** ¶ Design power factor of generating equipment¶

**a supprimé:** wind

**a supprimé:** upper and lower bounds

**a supprimé:** F

**a supprimé:** Decision

**a supprimé:**

[Technical Requirements for the Connection of Generating Stations to the Hydro-Québec Transmission System](#)

**a supprimé:** Technical Requirements for the Connection of Generating Stations to the Hydro-Québec Transmission System

Generators of a *generating station* that have an installed capacity of less than 10 MW and that are not required to contribute to voltage regulation, as stipulated in section 6.4.1, must supply sufficient reactive power to maintain a unity power factor on the high-voltage side of the switchyard.

### 7.6.2.2 [Other types of generating equipment](#)

For any other type of generating equipment—for example, [asynchronous generators](#)—the *generating station* must make available, on the high-voltage side of the switchyard, a range of reactive power corresponding to a leading and lagging power factor not exceeding 0.95. The reactive power available on the high-voltage side of the switchyard must at least correspond to a power factor of 0.95 of the rated power of the *generating units* in service. [The power producer must demonstrate that the reactive compensation technology used does not generate overvoltages or self-excitation, particularly during islanding.](#)

A *generating station* that has an installed capacity of less than 10 MW and that is not required to contribute to voltage regulation, as stipulated in section 6.4.1, must supply sufficient reactive power to maintain a unity power factor on the high-voltage side of the switchyard.

### [7.6.3 Harmonics](#)

[Note: For generating stations using SERMOs, requirements found in this section are superseded by those described in section 12.15.](#)

**a supprimé:** Harmonics produced by generation equipment...

*Synchronous generators* must comply with the harmonic testing requirements set out in International Electrotechnical Commission (IEC) standard 60034-1 – Rotating electrical machines [2] or their equivalent. *Asynchronous generators* must perform similarly. Their performance is to be confirmed by testing and documented in the test reports described in chapter 10 of this document.

### 7.6.4 [Inertia constant](#)

**a supprimé:** of generating units

The inertia constant of [turbine-generator generating units](#) within a *generating station* connected to the *Transmission System* must be compatible with the inertia constants of existing *generating stations* in the same region in order to maintain *Transmission System* stability and integrity during *disturbances*, and to minimize the risk of oscillations between *generating stations*. If needed, the *Transmission Provider* will specify, through the *interconnection study*, any minimum inertia constant that applies to *generating units* in the *generating station*.

## 7.7 Step-up transformers

### 7.7.1 Taps

Note: [For generating stations using SERMOs, requirements](#) found in this section are superseded by those described in section 12.13.

**a supprimé:** For wind generating stations, requirements

Unless otherwise stipulated at the time of the *interconnection study*, *generating station* step-up transformers must have [de-energized](#) taps that allow the transformer ratio to be adjusted according to voltage conditions on the *Transmission System*. Taps must be selected to avoid hampering present and future operation of the *Transmission System* and to meet section 6.1 requirements.

**a supprimé:** Decision

**a supprimé:**



[Technical Requirements for the Connection of Generating Stations to the Hydro-Québec Transmission System](#).

**a supprimé:** Technical Requirements for the Connection of Generating Stations to the Hydro-Québec Transmission System

### 7.7.2 Winding connections of step-up transformers

Winding connections of *generating station* step-up transformers must comply with requirements regarding *Transmission System* grounding connection set out in sections 7.1.1 or 7.1.2, as applicable.

### 7.7.3 Impedance values

Following the *interconnection study*, the *Transmission Provider* may specify (maximum or minimum) impedance limits for *generating station* step-up transformers, in accordance with requirements regarding *Transmission System* grounding connection described in sections 7.1.1 or 7.1.2, as applicable.

[In some cases, the \*Transmission Provider\* may also require the use of multiple lower nominal power step-up transformers having an unconnected secondary winding, to allow \*Transmission System\* line protection systems to function correctly.](#)

### 7.7.4 Energizing

[When a step-up transformer energizing study is required by the \*Transmission Provider\* in accordance with the \*Emission Limits for Disturbances on the Hydro-Québec Transmission System\*<sup>14</sup>, the power producer must indicate therein whether mitigation methods are required in order not to cause \*disturbances in the system\*, such as:](#)

- [the voltage dip defined in the \*Caractéristiques de la tension fournie par le réseau de transport d'Hydro-Québec\*<sup>15</sup>](#)
- [failure to comply with the \*Emission Limits for Disturbances on the Hydro-Québec Transmission System\*<sup>16</sup>](#)

[If applicable, the technical specifications and performance of the mitigation methods must be provided to the \*Transmission Provider\* for approval before procurement.](#)

[Also,](#) following the *interconnection study*, the *Transmission Provider* may require that the power producer *facilities* be equipped with means of mitigating closing transient *disturbances* (e.g., *overvoltage*) during step-up transformer energizing operations.

**a supprimé:** F

## 7.8 Voltage unbalances

[Power producer \*facilities\*, particularly \*synchronous generators\*, \*asynchronous generators\* and \*inverters\*, must be designed to withstand, without \*tripping\*, voltage unbalances of up to 2% \(negative-sequence component,  \$V2/V1\$ \) under steady-state conditions on the \*Transmission System\* and even greater unbalances for a limited time \(e.g., a 50% voltage unbalance under fault conditions\).](#)

**a déplacé (et inséré) [1]**

**a supprimé:** and

<sup>14</sup> As approved from time to time by the Régie de l'énergie.

<sup>15</sup> Reference provided for explanatory and information purposes only.

<sup>16</sup> As approved from time to time by the Régie de l'énergie.

**a supprimé:** supplied only

**a supprimé:** ve

**a supprimé:** Decision

**a supprimé:**

[Technical Requirements for the Connection of Generating Stations to the Hydro-Québec Transmission System](#)

**a supprimé:** Technical Requirements for the Connection of Generating Stations to the Hydro-Québec Transmission System

## 7.9 Possible Transmission System voltage changes

The *Transmission Provider* may change the nominal voltage of certain portions of its *Transmission System* from that used at the time the *generating station* is connected. [Conversion to a different nominal voltage may also require changes to the system's grounding connection.](#)

The *interconnection study* will mention any such planned voltage change. Power producer *facilities* must then be designed to adapt to the multiple voltage levels specified in the study.

## 7.10 Transmission line built by the power producer

To maintain *Transmission System* reliability and safety, a power producer building a transmission line to connect its *generating station* to the *Transmission System* must ensure the electrical and mechanical characteristics of the line in question are equivalent to those of a line the *Transmission Provider* would build for a comparable project. The *Transmission Provider* will supply the power producer with specific design requirements [\(EPC\)](#) based on the type of line and its planned location.

**a supprimé:** Decision

**a supprimé:**

**a supprimé:** Technical Requirements for the Connection of Generating Stations to the Hydro-Québec Transmission System

## 8 Protection system requirements

### 8.1 General principles

The power producer is responsible for adequately protecting its *facilities* from *disturbances* that may arise in its *facilities* or on the Hydro-Québec *Transmission System*.

The power producer must also procure and install within its *facilities* protection systems that can effectively protect the *Transmission System*.

Protections installed by the power producer must be coordinated among themselves and with *Transmission System* protection systems.

#### 8.1.1 Selectivity of power producer facility protection systems to Transmission System disturbances

Systems protecting power producer *facilities* must be selective enough to avoid any inadvertent *generating unit tripping* when *disturbances* occur. More specifically, no protection system must cause, directly or indirectly, *generating unit or compensation equipment tripping* for the voltage and frequency deviations given in tables 2, 3 and 4 of sections 6.3.1 to 6.3.3. Equipment that is not likely to be damaged by greater voltage and frequency variations must remain in service beyond the minimum values indicated in those tables.

#### 8.1.2 Automatic reclosing

Unless a special agreement has been reached with the *Transmission Provider* following the *interconnection study*, any automatic *reclosing* of a *generating station* is prohibited, regardless of whether the fault originates within those *facilities* or on the *Transmission System*.

### 8.2 Grounding connection

If the *generating station* is connected to the *Transmission System* through a *customer facility*, the *Transmission Provider* may require, besides effective neutral grounding, additional protection systems.

If the *generating station* is connected to a portion of the *Transmission System* with non-effective neutral grounding under normal conditions, appropriate protection systems are required.

### 8.3 Circuit breakers

All 230-kV or higher circuit breakers must have two sets of trip coils with separate cores, each designed for both automatic trip protection circuits. For voltage levels lower than 230 kV, two sets of trip coils with separate cores are required if *Transmission System* protection needs warrant it.

[Circuit breakers for transformers, shunt reactors and capacitors may have to have single-phase command \(and close/open specification\) in order to perform controlled closing and opening switching operations.](#)

[There could be a requirement to use a circuit breaker that does not close automatically when an SF6 gas leak occurs in order to prevent out-of-step closing.](#)

**a supprimé:** Decision

**a supprimé:**

[Technical Requirements for the Connection of Generating Stations to the Hydro-Québec Transmission System](#)

**a supprimé:** Technical Requirements for the Connection of Generating Stations to the Hydro-Québec Transmission System

[For the needs of the Transmission System, a circuit breaker that locks only the phase undergoing low SF6 gas pressure could be required in order to limit fault severity by allowing healthy phases to remain open.](#)

## 8.4 Protection functions related to Transmission System needs

Protection functions that must be implemented [in the power producer's protection system in order](#) to meet the needs of the *Transmission System* are described below. The protection systems in question must, for the zone they are to circumscribe, detect any kind of fault or *disturbance* that may affect the *Transmission System*, whether it originates in power producer *facilities* or on the *Transmission System*. Protection systems triggered in such situations must isolate the faulted zone from the *Transmission System*.

### 8.4.1 Protection from faults in power producer facilities

The protection systems the power producer uses to clear faults in its *facilities* must be compatible and coordinated with those used on the *Transmission System*. When triggered, power producer protection systems must quickly, reliably, selectively and safely isolate any kind of fault affecting the *facilities*.

### 8.4.2 Protection from faults on Transmission System

When triggered, the protection systems the power producer uses to clear faults occurring on the *Transmission System* must quickly, reliably, selectively and safely remove the contribution of the *generating station* to any kind of fault.

Two primary protections (as defined below), each equipped with a trip relay, are required. In some cases, the *Transmission Provider* may require the two primary protections [depending on the characteristics of the Transmission System near the generating station connection point](#).

**a supprimé:** provide a higher level of independence so as to meet the needs of the local

**a supprimé:** close to

**a supprimé:** to which

**a supprimé:** is connected

**a supprimé:** f

**a supprimé:** s

If the contribution of *generating units* (e.g., *asynchronous generators*) to the *Transmission System* fault is insufficient to allow the use of two primary protection systems, the appropriate protection solutions will be specified in the project-specific complementary technical requirements issued following the [Facilities Study](#).

Primary protections are comprised of relays with the following functions and settings:

- The protection must cover all types of faults: three-phase, two-phase, two-phase-to-ground, and phase-to-ground with and without a fault impedance. For high-impedance faults, the fault resistance used must be  $R_f = 10 \Omega$ , i.e., a zero-sequence component of  $3R_f = 30 \Omega$ .
- Operation must not be intentionally delayed except as may be required for coordination with *Transmission System* protection systems.
- Protection must be selective. The zone covered by the primary protection must be coordinated with protections in adjacent zones.

It is recommended that protection systems differ in design or in manufacturer. Such protection systems may require telecommunication links.

### 8.4.3 Voltage protection, frequency protection and remote tripping

Power producer *facilities* and the *Transmission System* require voltage and frequency protections. [These protections can also serve to detect islanding](#). A *remote tripping* system may also be required.

**a supprimé:** Decision

**a supprimé:**

[Technical Requirements for the Connection of Generating Stations to the Hydro-Québec Transmission System](#)

**a supprimé:** Technical Requirements for the Connection of Generating Stations to the Hydro-Québec Transmission System

### 8.4.3.1 Voltage protection

Note: [For generating stations using SERMOs, requirements](#), found in this section are superseded by those described in section 12.5.1.

**a supprimé:** For wind generating stations, requirements

Voltage protection must include both an undervoltage function and an overvoltage function.

Voltage protection settings for a *generating station* connected to the *Transmission System* must comply with steady-state voltage ranges given in section 6.1, as well as post-*disturbance* voltage [thresholds and their minimum duration](#), given in tables 2 and 3. [These settings must take into account the voltage gap resulting from the presence of a collector system, the step-up transformer and, where applicable, a tap changer.](#) Table 3 shows, for instance, that an overvoltage relay with the trip threshold set to a voltage range of [between 1.15 and 1.20 p.u.](#) must not trip unless the positive-sequence voltage on the high-voltage side of the switchyard remains continuously above the operating threshold for at least 30 seconds.

**a supprimé:** ranges

**a supprimé:** for the minimum durations

**a supprimé:** Table 3

**a supprimé:** (1.15 < V ≤ 1.20)

[If the protection functions used take into account a dead band between the pick-up threshold and the resetting of its timer, the setting used must take this dead band into account so as not to trip in the event of a disturbance briefly exceeding the pick-up threshold without dropping below the timer reset threshold.](#)

[It is allowable to use undervoltage and overvoltage protections based on root mean square \(RMS\) rather than on positive sequence to comply with voltage thresholds, provided that the tripping associated with each threshold can only occur when the undervoltage or overvoltage is present on all three phases simultaneously.](#)

It is not necessary to have settings for each of the values given in tables 2 and 3. [However, some thresholds may be specified in the complementary technical requirements in order to ensure generating station tripping for certain disturbances and following prolonged power loss to the protection system.](#)

### 8.4.3.2 Frequency protection

Note: [For generating stations using SERMOs, requirements](#), found in this section are superseded by those described in section 12.5.2.

**a supprimé:** For wind generating stations, requirements

Frequency protection must include both an underfrequency function and an overfrequency function. Protection settings must in no instance interfere with the measures implemented by the *Transmission Provider* to restore system frequency following a *disturbance*.

Frequency protection settings for a *generating station* connected to the *Transmission System* must comply with the steady-state frequency range given in section 6.2, as well as post-*disturbance* frequency [thresholds and their minimum duration](#), given in Table 4. Referring to Table 4, for instance, frequency protection with an operating threshold set [between 58.5 and 59.4 Hz](#) must have a minimum time-lag of 11 minutes. If a cycle-counting relay is used (rather than a time delay relay), the number of cycles must be set based on the [higher frequency threshold value](#).

**a supprimé:** ranges

**a supprimé:** for the minimum durations

**a supprimé:** Table 4

**a supprimé:** Table 4

**a supprimé:** in the frequency range (

**a supprimé:** ≤ F <

**a supprimé:** )

**a supprimé:** maximum

**a supprimé:** of the corresponding range

**a supprimé:** Table 4

**a supprimé:** Decision

**a supprimé:**

It is not necessary to have settings for each of the values given in Table 4.

These requirements also apply to a *generating station* connected to the distribution system, to *facilities* of a municipal system or of the SJBR electricity cooperative.

The power producer may use more sensitive underfrequency protection settings provided they are able to compensate any loss of generation. *Islanding* on the power producer's own load or load-shedding agreements with a third party may be used to offset loss of generation should underfrequency protection be tripped. The power producer must demonstrate to the *Transmission Provider* that appropriate procedures have been implemented and/or that automatic load-shedding agreements have been signed.

### 8.4.3.3 Remote tripping

The *Transmission Provider* may require that the power producer install a *remote tripping* system under the following circumstances:

- If the line *reclosing* time is short (less than 2 s)
- If unwanted *islanding* may occur
- As supplementary protection if existing power producer *facility* protections for *Transmission System* faults prove insufficiently effective or selective to ensure adequate protection of the *Transmission System*
- When the power producer's fault current contribution is insufficient to allow adequate operation of the *Transmission Provider's* protections
- If self-excitation may occur, as when *islanding* a *generating station* with a capacitive load (e.g., capacitor bank, filters, unloaded line or cable)

Failure of the *remote tripping* system may require *tripping* of the *generating station* or activation of additional line, voltage or frequency protection settings. Appropriate solutions for dealing with the consequences of a *remote tripping* system (telecommunications) failure shall be specified in the project-specific complementary technical requirements.

If *tripping* the *generating station* would lead to excessive *disturbances* on the *Transmission System*, the *Transmission Provider* may require that a second *remote tripping* system be installed.

These requirements also apply to a *generating station* connected to the distribution system, to *facilities* of a municipal system or of the SJBR electricity cooperative.

### 8.4.4 Breaker failure protection

Breaker failure protection or equivalent protection is required in order to allow breaker *tripping* in adjacent zones when a breaker used to meet *Transmission System* protection needs fails to trip.

A remote breaker failure protection system must be implemented using a dedicated link to remotely trip breakers at substations contributing to the fault, for faults in power producer *facilities*, if rapid *tripping* is needed to fulfill *Transmission System* requirements.

**a supprimé:** Technical Requirements for the Connection of Generating Stations to the Hydro-Québec Transmission System

**a supprimé:** are not

**a supprimé:** enough

**a supprimé:** Decision

**a supprimé:**

**a supprimé:** Technical Requirements for the Connection of Generating Stations to the Hydro-Québec Transmission System

#### 8.4.5 Protection from other phenomena

It is the power producer's responsibility to adequately protect its *facilities* from overvoltages and other harmful phenomena. Overvoltages may, for instance, be caused by the interaction between the *generating station* and the *Transmission System*, or arise from self-excitation of synchronous or *asynchronous generators*, harmonic or subsynchronous resonance, ferroresonance or (current or voltage) unbalances. The *Transmission Provider* may require that the power producer install various systems in its *facilities* to adequately protect the *Transmission System* and third-party *facilities* from such phenomena.

### 8.5 Equipment related to Transmission System protection requirements

#### 8.5.1 Protective and trip relays

Protective and trip relays used in protection systems required to meet *Transmission System* needs must be certified by the *Transmission Provider*. The *Transmission Provider* may, however, authorize for a specific project the use of relays with certification pending if it considers them acceptable.

Anti-*islanding* protective relays must only be used for that purpose.

#### 8.5.2 Protection system settings

The power producer must not modify settings for its protections without written authorization from the *Transmission Provider*. The power producer must carry out periodic checks of protective devices it has installed.

#### 8.5.3 Protection system power supply

Protection systems required for the *Transmission System* must be powered using a storage battery, or a pair of storage batteries if the *Transmission Provider* so requires based on *interconnection study* results, since such protection systems must remain functional should the station service supply fail.

Each storage battery must have two chargers that can either run in parallel with the battery or back up each other. Battery backup time must be at least eight consecutive hours for each battery. If station services can be resupplied from another source, battery backup time can be reduced to two or four hours, depending on how long it takes to do so.

#### 8.5.4 Voltage and current transformers

Current and voltage transformers must be installed on each of the three phases to power line protection systems installed to fulfill *Transmission System* needs. Such transformers must have separate secondary windings in order to power independently the two primary line protection systems. The power producer must submit voltage and current transformer specifications to the *Transmission Provider*, which will check that they comply with its current standards.

**a supprimé:** Decision

**a supprimé:**

## 8.6 Telecommunication systems for teleprotection functions

The *Transmission Provider* supplies, installs and maintains equipment required for transmitting teleprotection signals.

As shown by [Figure 4](#), the telecommunications junction point is the boundary point between the Hydro-Québec (or third-party) telecommunications network and the power producer's equipment. This point is generally located at the junction box (JB) connecting telecommunication equipment (at the end of the link) to the tone unit (TU) (when present) or to the protective relay of the power producer *facilities*.

The power producer must supply electrical power, as well as adequate secure space for installing all this equipment; the power producer must also install all required ductwork, junction boxes, as well as tone or teleprotection units that are part of the protection systems.

**Figure 4: Position of certain power producer devices relative to the telecommunications junction point**

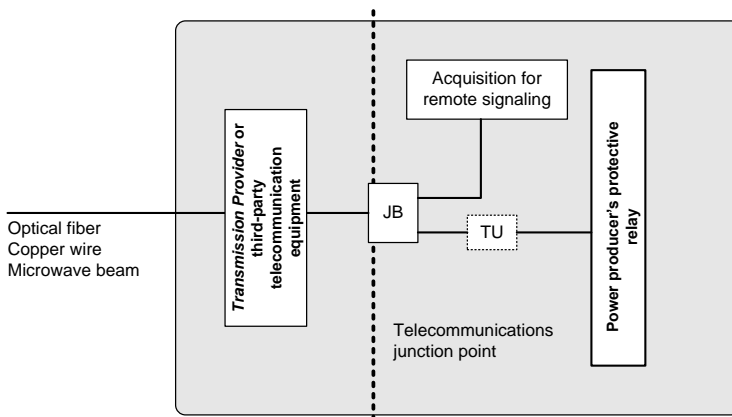

FOR REFERENCE PURPOSES ONLY

**a supprimé:** Technical Requirements for the Connection of Generating Stations to the Hydro-Québec Transmission System

**a supprimé:** Figure 4

**a supprimé:** Decision

**a supprimé:**



a supprimé: Technical Requirements for the Connection of Generating Stations to the Hydro-Québec Transmission System

## 9 Real-time operation requirements

### 9.1 Data required for real-time Transmission System operation

To operate the *Transmission System* efficiently, the *Transmission Provider* requires real-time data, in a form compatible with its equipment, from each *generating station* belonging to the power producer *facilities*. The data required depends on *generating station* capacity and is given in [Table 6](#).

a supprimé: Table 6

The power producer must provide and install in its *facilities* all sensors required to transmit the required data to the *Transmission Provider*. Upon request by the *Transmission Provider*, the power producer must take part in tests two months before the *generating station* is commissioned, or at any other date agreed upon with the *Transmission Provider*, to check that remote signaling is working properly.

The equipment used by the power producer to provide data required by the *Transmission Provider* is subject to the latter's approval.

Switchyard equipment must comply with the *Transmission Provider's* identification (nomenclature), which shall be provided to the power producer during project implementation.

**Table 6: Data required by the *Transmission Provider* for the telecontrol [center](#) (TC) and System Control [Center](#) (SCC)<sup>1,2</sup>**

a supprimé: centre

a supprimé: Centre

REQUIRED DATA	CAPACITY < 50 MW		CAPACITY ≥ 50 MW	
	TC	SCC	TC	SCC
Total <i>generating station</i> generation in MW and Mvar <a href="#">at connection point</a>		Measurement/ <a href="#">cal culation</a> Except if impact on <i>system</i> deemed negligible		Measurement/ <a href="#">cal culation</a>
<i>Generating unit</i> circuit breaker	State <sup>7</sup> If required for <i>system</i> operation		State <sup>7</sup>	State
<i>Generating unit</i> disconnect switch	State <sup>8</sup> If required for <i>system</i> operation		State <sup>8</sup>	State
<i>Generating unit</i> MW, Mvar, kV and A	Measurement <sup>9</sup> If required for <i>system</i> operation		Measurement <sup>9</sup>	Measurement <sup>9</sup>
Number of <a href="#">generating units</a> in service		Number		Number
Tie breaker	State Except if impact on <i>system</i> deemed negligible		State	State

a supprimé: wind generators

a supprimé: Decision

a supprimé:

[Technical Requirements for the Connection of Generating Stations to the Hydro-Québec Transmission System](#)

**a supprimé:** Technical Requirements for the Connection of Generating Stations to the Hydro-Québec Transmission System

REQUIRED DATA	CAPACITY < 50 MW		CAPACITY ≥ 50 MW	
	TC	SCC	TC	SCC
MW, Mvar, kV and A at connection point(s)	Measurement Except if impact on system deemed negligible		Measurement	Measurement
<a href="#">State of charge of an energy storage system</a>	<a href="#">Measurement</a>		<a href="#">Measurement</a>	<a href="#">Measurement</a>
Water level (fore- and tailbay)				Level
Generating unit P <sub>max</sub>				Measurement
Generation rejection, LFC <sup>3</sup> – other special protection systems			If controlled, state, measurement and control signals transmitted. To be specified, if applicable	If controlled, state, measurement and control signals transmitted. To be specified, if applicable
Acquisition unit	State		State	State
Telephone link (voice)	Note 4		Note 4	
Breaker or switch used as the station service supply point			State	
State and alarm signals <sup>5</sup>	State		State	
Stabilizer <sup>6</sup>			State If applicable	State If applicable

1. Requirements for remote control of *generating station* are not included, nor are those for generation management
2. For *generating stations* [using SERMOs](#) and *generating stations* with capacity lower than 50 MW, information sent to SCC may transit through [a](#) TC
3. Load-frequency control
4. Link to contact *generating station* operator 24/24 x 7/7 (directly, without extension number, ~~email~~ or voice mailbox)
5. Certain signals or alarms may be required to indicate the state of tone units or operation of protections (e.g., backup protection) that can affect [the](#) *Transmission System*
6. Signaling of stabilizer state is required wherever installed (see section 6.4.2)
7. Bus line feeder circuit breaker for [a](#) *generating station* [using SERMOs](#)
8. Bus line feeder disconnect switch for [a](#) *generating station* [using SERMOs](#)
9. [Active and reactive power measurement must be directional if an energy storage system is present](#)

**a supprimé:** wind

**a supprimé:** -

**a supprimé:** wind

**a supprimé:** wind

**a supprimé:** Decision

**a supprimé:**

[Technical Requirements for the Connection of Generating Stations to the Hydro-Québec Transmission System](#),

**a supprimé:** Technical Requirements for the Connection of Generating Stations to the Hydro-Québec Transmission System

[Active](#), and reactive power measurement requirements given in [Table 6](#), also apply to a *generating station* connected to the distribution system, to *facilities* of a municipal system or of the SJBR electricity cooperative.

**a supprimé:** Real

**a supprimé:** Table 6

Section 12.6 covers specific [additional](#) information required for the real-time operation of *generating stations* using [SERMOs](#).

**a supprimé:** wind

## 9.2 Telecommunication systems for operations functions

The *Transmission Provider* generally supplies and installs telecommunication equipment needed to transmit, from power producer *facilities*, data enabling it to operate the *Transmission System* effectively. The *Transmission Provider* is also responsible for the maintenance of any such equipment.

As shown by [Figure 4](#), in section 8.6, the telecommunications junction point is the boundary point between the Hydro-Québec (or third-party) telecommunications network and the power producer's equipment. This point is generally located at the junction box (JB) connecting telecommunication equipment (at the end of the link) to the power producer equipment used to acquire remote signaling data.

**a supprimé:** Figure 4

The equipment to install, interface points and other characteristics relevant to providing the required services will be specified to the power producer at the [Facilities Study](#) stage.

**a supprimé:** f

**a supprimé:** s

The power producer must provide adequate secure space for installing all this equipment, and [must](#) install all required ductwork and junction boxes. [The power producer must also provide the power supply to these systems](#).

**a supprimé:** Decision

**a supprimé:**

**a supprimé:** Technical Requirements for the Connection of Generating Stations to the Hydro-Québec Transmission System

## 10 Verification of compliance with requirements

### 10.1 Verification by the Transmission Provider

The *Transmission Provider* shall be authorized to verify that systems and equipment installed by the power producer in the *generating station* to meet *Transmission Provider* requirements are working properly, including data *Transmission Systems* and the settings of protection systems, speed governors ([frequency regulation for a generating station using SERMOs](#)), voltage regulators and stabilizer, etc.

### 10.2 Verification by the power producer

The power producer must make all necessary verifications to demonstrate that its *facilities* comply with *Transmission Provider* requirements.

Two types of verifications are required:

a) **Initial verifications**

During *generating station* startup or following a substantial change of an existing *generating station*, the power producer must verify that its *facilities* meet *Transmission Provider* requirements and achieve stated levels of performance.

b) **Periodic verifications**

At intervals set by the *Transmission Provider*, the power producer must verify that its *facilities* have maintained their characteristics and their levels of performance.

Such verifications also aim to ensure that information submitted to the *Transmission Provider* for steady-state and dynamic modeling of *generating stations*, in the course of its dynamic simulation studies, matches the actual equipment characteristics. *Transmission Provider* requirements regarding verification and validation of models and power producer equipment are set out in Appendix F.

To facilitate such verifications, the power producer must anticipate the required means and tools: measurement points, data archiving, ways to isolate regulation and protection systems, test signal input points, etc.

Periodic verifications also include checking underfrequency trip relay settings for all 20-MW or higher *generating units*, at intervals not exceeding those given in [Table 7](#).

**a supprimé:** Table 7

**a supprimé:** Decision

**a supprimé:**

**Table 7: Maximum intervals between period checks of underfrequency trip relays for 20 MW or more generating units**

	Protection functions provided by a set of components		
	Without self-monitoring or self-checking capabilities <sup>1</sup>	With self-monitoring or self-checking capabilities (Digital microprocessor technology) <sup>2</sup>	With self-monitoring or self-checking capabilities (Digital microprocessor technology) <sup>3</sup>
<b>All protection groups</b>	<b>6 years</b>	<b>12 years</b>	<b>12 years</b>
<p>1. Analog signal processing and logic functions are implemented using either electromechanical or electronic components, or both types of components. Protection functions that are implemented using components without self-monitoring capabilities include electromechanical relays and electronic relays (or static relays).</p> <p>2. Analog signal processing and logic functions are performed digitally using microprocessors. Digital components have self-monitoring or self-checking capabilities for their analog or digital modules, as well as their logic functions. Any anomaly is reported through an alarm raised at the control center. Personnel on duty round the clock is able to perform any required verification should a problem arise.</p> <p>3. Analog signal processing and logic functions are performed digitally using microprocessors. In addition to the characteristics described in Note 2, digital components must have self-monitoring or self-checking capabilities covering the integrity of AC voltage and current signals. Any anomaly is reported through an alarm raised at the control center. Personnel on duty round the clock is able to perform any required verification should a problem arise.</p>			

a supprimé: Technical Requirements for the Connection of Generating Stations to the Hydro-Québec Transmission System

a supprimé: M

a supprimé: M

a supprimé: (Note 3)

a supprimé: (Note 1)

a supprimé: (Note 2)

a supprimé: 4

a supprimé: 6

a supprimé: 8

a supprimé: centre

a supprimé: centre

### 10.3 Power producer equipment test reports

Before commissioning its *generating station*, the power producer must submit to the *Transmission Provider* test reports for its equipment to demonstrate that its *facilities* comply with the requirements described herein.

The power producer must specifically supply to the *Transmission Provider* test measurements for the electrical characteristics of its equipment as given below:

- For step-up transformers supplied by the power producer, a copy of manufacturer test reports giving:
  - Rated power and voltage, and power at each tap
  - Number of taps and regulation range for each tap
  - Impedance (resistance and reactance) at each tap, including zero-sequence impedance if type tests have been run
  - Exciting current (at 80%–160% of rated voltage: the current can be measured, calculated or simulated)
  - Windings connection
  - Copy of each transformer's nameplate
- For *synchronous* and *asynchronous generators*, harmonic test results, in accordance with section 7.6.3.

a supprimé: 15

a supprimé: Decision

a supprimé:

[Technical Requirements for the Connection of Generating Stations to the Hydro-Québec Transmission System](#)

- For *generating units*:
  - Validation tests required by the *Transmission Provider* regarding [generation equipment](#) capacity and characteristics; voltage regulator, excitation system, stabilizer and speed governor [\(or frequency regulator\)](#) parameters etc. are specified to the power producer for each *generating station* connection project based on the type of generating equipment used. Such tests must allow validation of the dynamic models and associated parameters supplied by the power producer to the *Transmission Provider*.

**a supprimé:** Technical Requirements for the Connection of Generating Stations to the Hydro-Québec Transmission System

**a supprimé:** *synchronous* and *asynchronous* generator

**a supprimé:** Decision

**a supprimé:**

## 11 Requirements regarding event recorders

Line protection relays certified by the *Transmission Provider* have event and disturbography recording capabilities. The power producer must extract and archive data recorded by line protection relays that protect the *Transmission System* and supply such data to the *Transmission Provider* on request following any event. The power producer must further retain such recordings by systematically collecting them following each line protection relay *tripping*.

Within 10 business days, the power producer must forward the data indicated below to the following email address: [terapporteveproducteur@hydroquebec.com](mailto:terapporteveproducteur@hydroquebec.com):

- Any difference between the time recorded by the relay and the real time
- COMTRADE format files of the disturbography function
- Event recording files
- [The generating station's pre-fault conditions](#)

The *Transmission Provider* shall supply settings required to implement this function.

The *Transmission Provider* may require that the power producer incorporate into its *facilities* dedicated event analysis instruments (e.g., event loggers, *disturbance* recorders). [The power producer must make switchyard voltage and current measurements available. It must also make available signals from switchyard protections and control systems \(e.g., enabling of "crowbar" and "DC chopper" protections, or inverter tripping\) in order to start the recording.](#)

**a supprimé:** Technical Requirements for the Connection of Generating Stations to the Hydro-Québec Transmission System

**a supprimé:** agrees to

**a supprimé:** a reasonable time frame that shall not exceed

**a supprimé:** Decision

**a supprimé:**

## 12 Complementary requirements specific to generating stations using SERMOs

The requirements described in this section cover complementary technical aspects specifically related to generating stations using SERMOs. They either complement or supersede requirements described in other sections that contain a reference to chapter 12.

### 12.1 Switchyard

Figure 5 below is a diagram of a switchyard for a generating station using SERMOs connected to the Transmission System.

Figure 5: Switchyard for a generating station using SERMOs

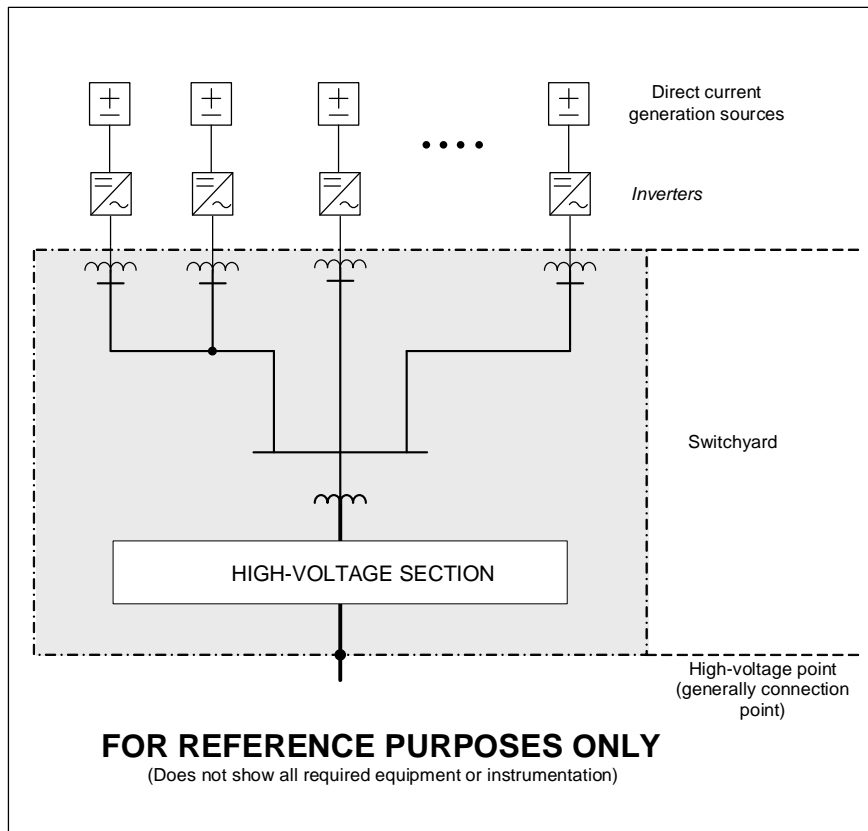

a supprimé: Technical Requirements for the Connection of Generating Stations to the Hydro-Québec Transmission System

a supprimé: wind

a supprimé: wind

a supprimé: Figure 5

a supprimé: wind

a supprimé: Wind g

a supprimé: switchyard

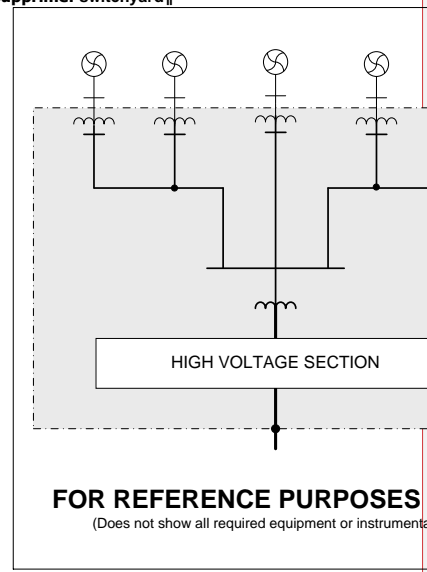

a supprimé: Decision

a supprimé:



Technical Requirements for the Connection of Generating Stations to the Hydro-Québec Transmission System.

In addition to the description given in section 5.1, and strictly for the purpose of applying technical requirements, the switchyard is deemed to include any compensation equipment added by the power producer to the *generating station* in order to comply with requirements described in the sections below.

**12.2 Response of generating station using SERMOs to disturbances on the Transmission System**

*Generating stations using SERMOs* must remain in service, without *generating unit tripping*, directly or indirectly, when voltage and frequency deviations occur (i.e., during and after these variations) following a disturbance, for the durations given in Figure 6, and tables 8, 9 and 10. *Generating station equipment includes energy sources, inverters, the various auxiliary systems, control systems, harmonic filters and compensation equipment.*

**12.2.1 Response of generating station using SERMOs during low voltage ride through (LVRT)**

All *equipment of a generating station using SERMOs* must remain in service during undervoltages that occur, following a disturbance for the durations indicated in Table 8.

**Table 8: Minimum durations during which a generating station using SERMOs must remain in service when undervoltage occurs**

<u>Undervoltage (p.u.)<sup>1</sup></u>	<u>Minimum duration (seconds)</u>
$0.9 \leq V \leq 1.0$	Continuously
$V < 0.9$	30
$V < 0.85$	2.0
$V < 0.75$	1.0
$V < 0.25$	$3.4 * V \text{ (p.u.)} + 0.15$

1. Positive-sequence voltage on the high-voltage side of the switchyard.

Figure 6 thus defines the required low voltage response capacity of a *generating station using SERMOs* in the event of a balanced or unbalanced-grid fault on the *Transmission System* (including the high-voltage side of the switchyard), during both the fault itself and the voltage recovery period after it has been cleared. For information purposes, faults listed below are especially taken into account:

- Three-phase fault cleared in 0.15 s
- Two-phase fault or two-phase-to-ground fault cleared in 0.15 s
- A multiphase fault that becomes a single-phase fault after 0.15 s cleared in an additional 0.15 s
- Phase-to-ground fault cleared in 0.3 s
- Any fault cleared by slow protection whose positive-sequence voltage on the high-voltage side of the switchyard may reach  $(t-0.15)/3.4$  (for t of between 0.15 s and 0.75 s)

a supprimé: Technical Requirements for the Connection of Generating Stations to the Hydro-Québec Transmission System

a supprimé: wind

a supprimé: Wind generating

a supprimé: response

a supprimé: Wind

a supprimé: wind generator

a supprimé: Figure 6

a supprimé: 7 and 8

a supprimé: Wind

a supprimé: response

a supprimé: wind

a supprimé: equipment

a supprimé: when,

a supprimé: the positive-sequence voltage on the high-voltage side of the switchyard remains above the continuous curve in Figure Figure 6

a supprimé: No blocking of wind generators or any other equipment is authorized unless agreed otherwise with the *Transmission provider*.¶ Within the hatched area in Figure 6 (which extends to 0.75 s, and includes the area delimited by dotted lines between 0.15 and 0.3 s), low voltage ride through requirement is based on the measurement of each phase-to-ground voltage on the high-voltage side of the switchyard.

a supprimé: Figure 6

a supprimé: wind

a supprimé: with a residual phase-to-ground voltage

a supprimé: cleared in

a supprimé: Decision

a supprimé:

Technical Requirements for the Connection of Generating Stations to the Hydro-Québec Transmission System

If a power producer, due to its choice of technology and equipment manufacturer, proposes and guarantees its capacity to remain in service without tripping for faults or voltage dips longer than those described in this section, this increased capacity will be taken into account in order, wherever possible, to reduce additions or changes to protection and telecommunications systems to be made to the Transmission System for connection of the generating station.

**a supprimé:** Technical Requirements for the Connection of Generating Stations to the Hydro-Québec Transmission System

**a supprimé:** A necessity to remain in service during longer faults or voltage dips may be agreed upon with the power producer if such a solution is more advantageous overall.

**a supprimé:** Decision

**a supprimé:**

Figure 6: Low voltage ride through during which the **generating station using SERMOs** must remain in service following a **disturbance**

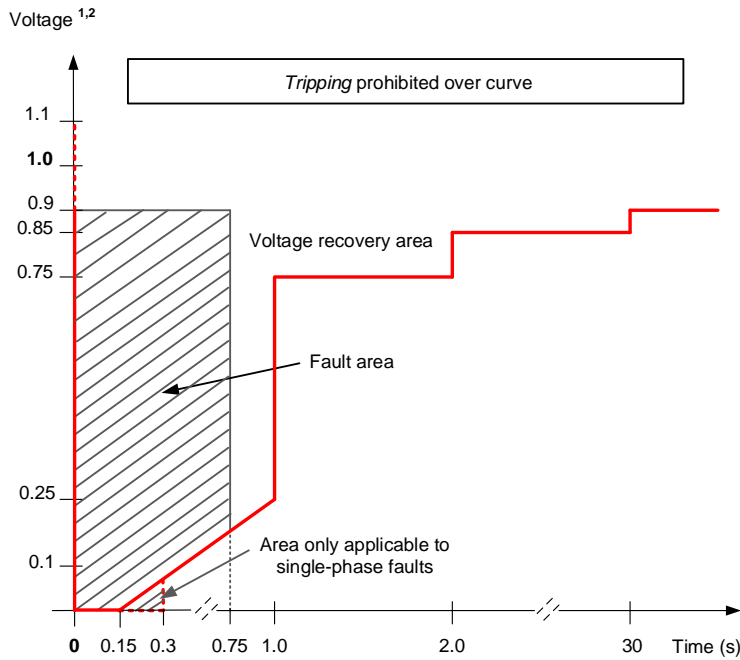

1. Positive-sequence voltage on high-voltage side of switchyard

**a supprimé:** Technical Requirements for the Connection of Generating Stations to the Hydro-Québec Transmission System

**a supprimé:** wind

**Commenté [A3]:** Deletion of «undervoltage» from title; deletion of note 2.

### 12.2.1.1 Inverter blocking during undervoltage and power resumption

During an undervoltage *disturbance*, if the positive-sequence voltage drops to 0.1 p.u. on the high-voltage side of the switchyard, the *inverters* may go into temporary blocking mode during which no current will be exchanged with the *system*. A temporary *inverter* blocking threshold of higher than 0.1 p.u. may be imposed by the *Transmission Provider*. In the event of temporary blocking, the *inverters* must return to normal functioning not later than 5 cycles after the voltage has risen above the blocking threshold (0.1 p.u. or another value imposed by the *Transmission Provider*). Return to active and reactive power at 90% of the pre-*disturbance* level must be distinctly adjustable between 0.05 and 5 seconds. The *Transmission Provider* will supply the settings to be observed for the resumption of active and reactive power based on the characteristics of the *Transmission System* near the *generating station* connection point.

**a supprimé:** Decision

**a supprimé:**

**a supprimé:** Technical Requirements for the Connection of Generating Stations to the Hydro-Québec Transmission System

### 12.2.1.2 Successive faults during a disturbance

During an undervoltage *disturbance* as described in section 12.2.1, the *generating station* and all its equipment must remain in service without *generating unit tripping* in the event of a series of faults that could result, particularly, in the *reclosing* of a transmission line on a permanent fault. When the positive-sequence voltage on the high-voltage side of the switchyard falls:

- to 0.25 p.u., the *generating station* must be capable of tolerating as many faults as may occur with a cumulative duration of up to the minimum durations required in Table 8
- below 0.25 p.u., the *generating station* must be capable of tolerating two successive faults

This requirement is measured over a 30-second window of time starting at the moment of the *disturbance* and resetting at the end of this period of time.

### 12.2.2 Response of a generating station using SERMOs during overvoltage

All equipment of the *generating station* must remain in service when overvoltages occur following a *disturbance* for the durations given in Table 9.

**a supprimé:** Wind generating station r

**a supprimé:** during overvoltage

**a supprimé:** wind

**a supprimé:** equipment

**Table 9: Minimum durations during which a generating station using SERMOs must remain in service when overvoltage occurs**

Overvoltage (p.u.) <sup>1</sup>	Minimum duration (s)
$1.0 \leq V \leq 1.10$	Continuously
$V > 1.10$	300
$V > 1.15$	30
$V > 1.20$	2
$V > 1.25$	0.10
$V > 1.40$ <sup>2,3</sup>	0.033

1. Positive-sequence voltage on high-voltage side of switchyard.

**a supprimé:** Overvoltage ranges (V) and minimum durations during which all wind generation station equipment must remain in service following a disturbance...

**a supprimé:** Permanently

**a supprimé:**  $< V \leq 1,15$

**a supprimé:**  $< V \leq 1,20$

**a supprimé:**  $< V \leq 1,25$

**a supprimé:**  $< V \leq 1.40$ <sup>2</sup>

#### 12.2.2.1 Inverter blocking during overvoltage and resumption of power

During an overvoltage *disturbance*, if the positive-sequence voltage rises to 1.25 p.u. on the high-voltage side of the switchyard and only after a duration of 0.022 seconds, the *inverters* may go into temporary blocking mode during which no current will be exchanged with the *system*. Temporary blocking is also permissible if initiated by an overvoltage greater than 1.4 p.u. (RMS) measured phase-to-ground at the *inverter* terminals that may appear on one or more phases and only after a minimum duration of 0.022 seconds. In the event of temporary blocking, the *inverters* must return to normal functioning not later than 5 cycles after the positive-sequence voltage has fallen back below 1.25 p.u. Return to active and reactive power at 90% of the pre-*disturbance* level must be distinctly adjustable between 0.05 and 5 seconds. The *Transmission Provider* will supply the settings to be observed for the resumption of active and reactive power based on the characteristics of the *Transmission System* near the *generating station connection point*.

**a supprimé:** Decision

**a supprimé:**

[Technical Requirements for the Connection of Generating Stations to the Hydro-Québec Transmission System](#)

**a supprimé:** Technical Requirements for the Connection of Generating Stations to the Hydro-Québec Transmission System

### 12.2.2.2 Current injection during disturbances

During a disturbance, if there is no inverter blocking, the generating station must be able to inject reactive current (capacitive or inductive) depending on the severity of the disturbance measured at the inverter up to its maximum transient capacity in order to contribute to bringing the voltage towards its nominal value, to reduce the voltage unbalance and to allow protections to function properly.

To inject positive- and negative-sequence current during faults, generating stations using SERMOs must comply with the sections “Current injection during ride-through mode” and “Performance specifications” (sections 7.2.2.3.4 and 7.2.2.3.5) of standard IEEE-P2800 [3].

### 12.2.3 Response of generating station using SERMOs to frequency variations

All equipment of the generating station must remain in service when frequency variations occur following a disturbance for the durations given in [Table 10](#).

The generating station must in addition remain in service during a system frequency variation ranging from -4 Hz/s to +4 Hz/s following a disturbance.

**a supprimé:** Wind generating station r

**a supprimé:** wind

**a supprimé:** equipment

**a supprimé:** Table 9.

**a supprimé:** wind

**Table 10: Minimum durations during which a generating station using SERMOs must remain in service when frequency variations occur.**

Frequency (Hz)	Minimum duration
$F \geq 61.7$	Instantly
$F > 61.5$	1.5 min
$F > 60.6$	11 min
$59.4 \leq F \leq 60.6$	Continuously
$F < 59.4$	11 min
$F < 58.5$	1.5 min
$F < 57.5$	10 s
$F < 57.0$	2 s
$F < 56.5$	0.35 s
$F < 55.5$	Instantly

**a supprimé:** Requirements regarding frequency variations also apply to a wind generating station connected to the distribution system, to facilities of a municipal system or of the SJBR electricity cooperative. ¶ 9

**a supprimé:** Frequency ranges (F) and minimum durations during which all wind generating station equipment must remain in service following a disturbance...

**a supprimé:**  $< F < 61.7$

**a supprimé:**  $< F \leq 61.5$

**a supprimé:** Permanently

**a supprimé:**  $58.5 \leq$

**a supprimé:**  $57.5 \leq$

**a supprimé:**  $57.0 \leq$

**a supprimé:**  $56.5 \leq$

**a supprimé:**  $55.5 \leq$

1. The term “instantly” refers to permission to issue a tripping order without intentional delay, but only after measuring and calculating the frequency with sufficient reliability to be immune from phase jumps and other transient phenomena. This requires the use of efficient filtering algorithms and minimal processing time, typically between 3 and 6 cycles (50–100 ms).

Requirements regarding frequency variations also apply to a generating station using SERMOs connected to the distribution system or to facilities of a municipal system or of the SJBR electricity cooperative.

### 12.3 Voltage regulation and power factor

A generating station using SERMOs must contribute to Transmission System voltage regulation in a continuous, dynamic and quick manner.

**a supprimé:** The

**a supprimé:** wind

**a supprimé:** Decision

**a supprimé:**

Technical Requirements for the Connection of Generating Stations to the Hydro-Québec Transmission System.

The voltage regulation function must operate continuously and without sudden fluctuations to regulate the voltage on the high-voltage side of the switchyard.

Thus, a generating station using SERMOs must be equipped with an automatic voltage regulation function. This function must allow the generating station to supply and absorb, in normal operation, the amount of reactive power corresponding to a leading and lagging power factor less than or equal to 0.95, as seen on the high-voltage side of the generating station switchyard, both when the generating station injects active power at the connection point and when it absorbs active power (hybrid generating station or energy storage system). The voltage regulation function must have a permanent droop adjustable between 0% and 10% and be based on the required reactive power.

Reactive power must be available over the full voltage and frequency range under normal operating conditions (voltage: 0.9–1.1 p.u.; frequency: 59.4–60.6 Hz). However, as shown in Figure 7, at voltages less than 0.95 p.u., the generating station is not required to absorb reactive power corresponding to a lagging power factor of 0.95. It still must be able to supply reactive power corresponding to a leading power factor of 0.95. Similarly, at voltages greater than 1.05 p.u., the generating station is not required to supply reactive power corresponding to a leading power factor of 0.95, but it still must be able to absorb the reactive power corresponding to a lagging power factor of 0.95.

Figure 7: Reactive power available on high-voltage side of switchyard vs. positive-sequence voltage in normal operation

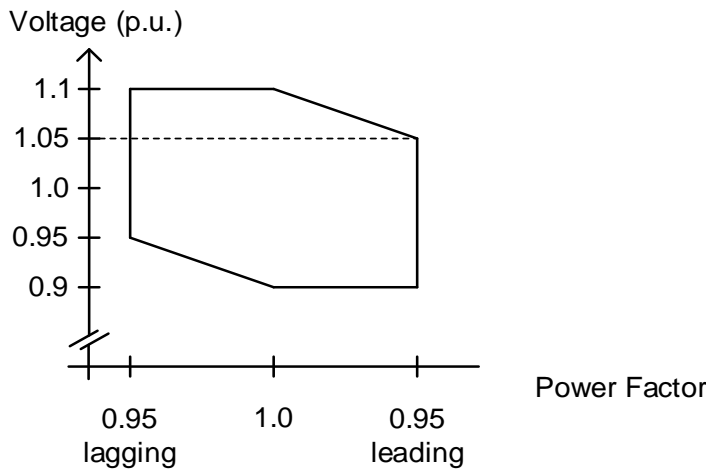

In addition to the requirement illustrated in Figure 7, the reactive power available on the high-voltage side of the switchyard with relation to the active power injected or absorbed by the generating station must reach at least ±0.33 p.u. of the total rated power of the generating units in service (equivalent to a power factor of 0.95).

a supprimé: Technical Requirements for the Connection of Generating Stations to the Hydro-Québec Transmission System

a supprimé: system

a supprimé: so as

a supprimé: the wind

a supprimé: system

a supprimé: It

a supprimé: be able

a supprimé: wind

a supprimé: system

a supprimé: Figure 7

a supprimé: wind

a supprimé: , as shown in Figure 7

a supprimé: wind

Commenté [A4]: Format of figure improved.

a supprimé: satisfying the concept

a supprimé: Figure 7

a supprimé: ,

a supprimé: variable

a supprimé: real

a supprimé: of wind generators in service,

a supprimé: reach

a supprimé: (i.e., an equivalent power factor of 0.95)

a supprimé: wind generators

a supprimé: , as shown in Figure 8

a supprimé: Decision

a supprimé:

[Technical Requirements for the Connection of Generating Stations to the Hydro-Québec Transmission System](#)

The reactive power available on the high-voltage side of the switchyard must comply with the present requirement as soon as the number of *generating units* in service is sufficient to compensate for the excess of reactive power generated by the collector system—this for any active power injected or absorbed by the *generating station*. However, the *Transmission Provider* can require the power producer to install reactive compensation equipment required to reduce or cancel out the reactive power generated by its *facilities* when all *generating units* are off-line or on standby.

In the case of a hybrid *generating station* or an energy storage system, the available reactive power takes into account the discharge (injection) and charge (absorption) active power, which may be different.

Exceptions to the present requirement apply:

- Type III wind generators are not required to supply a reactive power contribution if the active power injected is 10% or lower.
- When *generating units* are on standby (connected but without injection of active power), voltage regulation is not required. A storage system is never considered to be on standby.

If the *interconnection study* shows that reactive power from the *generating station* cannot be completely used on the *Transmission System*, the *Transmission Provider* may accept a power factor greater than 0.95 though not exceeding 0.97.

Dynamic regulation cannot rely on the *mechanical closing or tripping* of a shunt device. Furthermore, some parts of the *Transmission System* do not allow the addition of banks of shunt capacitors (it is up to the *Transmission Provider* to settle this issue).

Voltage regulation in a *generating station* may be assured by the *generation equipment* or by other equipment (e.g., synchronous compensator or STATCOM) added to the *generating station* by the power producer. No matter what design is adopted, voltage regulation performance of a *generating station* must always meet the requirements set out in this section.

A wind *generating station* with an *installed capacity* of less than 10 MW must be able to be operated at a constant power factor determined by the *Transmission Provider* so that a *generating station* whose automatic voltage regulation is disabled, including following a *disturbance*, can be operated permanently or during a period of work. The impact on the system of the disabling of voltage regulation on the response performances of a *generating station* experiencing undervoltages (section 12.2.1) and overvoltage responses (section 12.2.2) will then be taken into account by the *Transmission Provider*. Moreover, the *Transmission Provider* may waive the requirement for an automatic voltage regulation *function*, especially when the short-circuit level at the connection point is much higher than the *installed* capacity of the *generating station*, after completing the *interconnection study*. The wind *generating station* must then supply sufficient reactive power to maintain a unity power factor on the high-voltage side of the switchyard, including following a *disturbance*.

In addition to the requirements described above, the *Transmission Provider* requires that values be assigned to the parameters of the voltage regulation function in order to attain the desired performances in the system in normal operation and during *disturbances*, as defined in Table 11.

**a supprimé:** Technical Requirements for the Connection of Generating Stations to the Hydro-Québec Transmission System

**a supprimé:** Figure 8: Reactive power available on high-voltage side of switchyard vs. real power of wind generators in service¶

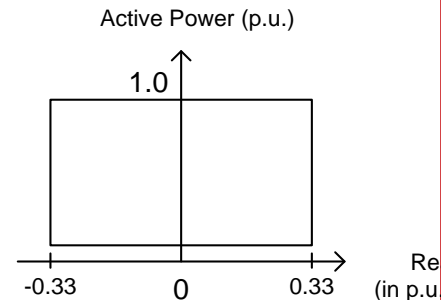

**a supprimé:** wind

**a supprimé:** The voltage regulation system must be designed to ensure any reactive power supplied or absorbed by a wind *generating station* reaches 63% of its final value within a delay of approximately 0.033 s in the advent of a large and sudden voltage variation on the *Transmission System*. The power producer must apply the voltage regulation system settings given by the *Transmission provider*.¶

**a supprimé:** wind

**a supprimé:** wind generator itself

**a supprimé:** wind

**a supprimé:** In the case of

**a supprimé:** rated power

**a supprimé:** system

**a supprimé:** rated

**a supprimé:** wind

**a supprimé:** Decision

**a supprimé:**

**a supprimé:** Technical Requirements for the Connection of Generating Stations to the Hydro-Québec Transmission System

**Table 11: Performance parameters associated with the voltage regulation function of a generating station using SERMOs**

Parameter	Description	Voltage regulation performance requirements	
		Normal operation <sup>1</sup>	During disturbances <sup>4</sup>
Reaction time	Time between a voltage variation and the start of the <i>generating station's</i> response to that voltage variation	< 200 ms <sup>2</sup>	< 16 ms <sup>2</sup>
Response time	Time between the start of the response to a voltage variation and the moment when the reactive power reaches 90% of its final value	< 30 s <sup>3</sup>	≤ 100 ms <sup>3</sup>
Damping	Damping ratio ( $\zeta$ ) of reactive power swings guaranteeing the stability of the response to a voltage variation	0.3 <sup>3</sup>	n/a
Settling band	Maximum difference in reactive power once stabilized from the final value required	n/a	-2.5% / +10% of the <i>generating unit's</i> maximum current

1. During voltage variations when the *system* voltage is kept within normal operating limits, generally between 0.9 p.u. and 1.1 p.u.  
 2. Does not apply to type III wind generators.  
 3. Varies depending on the characteristics of the *Transmission System* near the *generating station* connection point. The *Transmission Provider* supplies the settings to be applied by the power producer.  
 4. During sudden variations in *system* voltage outside normal operating limits detected at the terminals of the *generating station's* *generating units*.

See also section 12.2.2.2 for requirements regarding reactive current injection during *disturbances*.

## 12.4 Frequency control

~~Generating stations using SERMOs with installed capacity greater than 10 MW must be designed with the following frequency control functions:~~

- ~~primary frequency control for all SERMO technologies (section 12.4.1)~~
- ~~inertial response for wind generating stations only (section 12.4.2)~~

~~Effective frequency control at the connection point, during a disturbance, must correspond to the (absolute) maximum value of the primary and inertial response control functions.~~

~~If a generating station having installed capacity of 10 MW or less is equipped with frequency control functions, the Transmission Provider may require these to be permanently disabled, including following a disturbance, in order to prevent the formation of unwanted islanding.~~

~~Frequency control functions must not restrict the generating station's capacity to supply the required reactive power in steady state and during disturbances.~~

**a supprimé:** Wind

**a supprimé:** g

**a supprimé:** a rated

**a supprimé:** power

**a supprimé:** equipped with a

**a supprimé:** system

**a supprimé:** ¶  
Such a system enables wind *generating stations* to help restore system frequency in the advent of *disturbances* and thus maintain the current level of performance with regards to frequency control on the *Transmission System*.¶  
Different requirements apply to underfrequency conditions (during which the system relies on the inertial response of wind generators) and overfrequency conditions (where the system relies on continuous frequency regulation).¶

**a supprimé:** Decision

**a supprimé:**



Technical Requirements for the Connection of Generating Stations to the Hydro-Québec Transmission System.

**a supprimé:** Technical Requirements for the Connection of Generating Stations to the Hydro-Québec Transmission System

The power producer must apply the frequency control function settings supplied by the *Transmission Provider*.

Frequency control requirements also apply to *generating stations* using *SERMOs* connected to the distribution system, to the *facilities* of a municipal system or of the SJBR electricity cooperative.

#### **12.4.1 Primary frequency control**

*Generating stations* using *SERMOs* must have a primary frequency control function allowing the active power output injected or absorbed (for a storage system) at the connection point to be varied autonomously and dynamically, depending on deviations in the *system* frequency. Frequency control must act in both overfrequency and underfrequency situations. During underfrequencies, control must act only when, at the time of frequency deviation, there is headroom, as described in section 12.12. When a *generating station* is operated with headroom, this must be able to be maintained dynamically, depending on the variability of output. In addition, as indicated in section 12.11, the *Transmission Provider* may also require that a limit on active power be temporarily maintained in certain operating conditions of the *Transmission System* (e.g., thermal constraints). The primary frequency control function must have priority over this limiting function and use all available energy as needed.

The function must have a permanent droop, based on the *generating station's* installed capacity, with a range that can be set from 0 to 5%, and dead band thresholds for enabling and disabling, adjustable between 0 and 1.0 Hz and this, separately for overfrequency and underfrequency regulation. The function must be able to use the equipment's temporary overload capacity, when available.

Upon restoration of the *system* frequency at the dead band disabling value, the *generating station's* power will be restored to the value prior to the *disturbance* or to currently available power, in compliance with the requirement regarding ramp management during power variations in normal operation, described in section 12.8.

An energy storage system must perform primary frequency control both when it is charging (absorbing power) and when it is discharging (injecting power). This means that the system may have to invert its power depending on whether it is charging or discharging at the time of the *disturbance*.

Primary frequency control may be performed at the level of each *generating unit* or by means of a centralized system that controls *generating units* individually and optimizes their participation.

Frequency control by the *generating station* is required as long as the primary energy source (wind, solar irradiation, etc.) is available at the time of and during a *disturbance*.

In addition, the primary frequency control function must meet the performances set out in Table 12, while aiming at the best performances that the generation technology concerned can provide.

**a supprimé:** Decision

**a supprimé:**

**a supprimé:** Technical Requirements for the Connection of Generating Stations to the Hydro-Québec Transmission System

**Table 12: Performance parameters associated with the primary frequency control function of a generating station using SERMOs**

Parameter	Description	Function performance requirements	
		wind	other SERMOs
Reaction time	Time between detection of the system's frequency deviation and the start of the generating station's response to that frequency deviation	< 500 ms	< 200 ms
Response time	Time between any step in system frequency and the moment when the active power responding to that frequency deviation reaches 90% of its final value	< 4 s	< 1 s
Damping	Damping ratio ( $\zeta$ ) of active power swings guaranteeing the stability of the response to a system frequency deviation	> 0.3	> 0.3
Operating range	Extent of the generating station's production or absorption range during which the regulation function must be operational	Between minimum power and 100% <sup>1</sup> of the generating station's installed capacity	
Repetition	Capacity of the regulation function to be enabled several times successively	If required by the Transmission Provider, after a time equal to 200% of the previous duration of operation or per agreement with the Transmission Provider	

1. May be greater than 100% if a temporary equipment overload is available.

#### 12.4.2 Inertial response of wind generating stations.

**a supprimé:** Underfrequency control (inertial response)

The inertial response of wind generating stations takes the form of a momentary overproduction coming mainly from energy stored in rotating machinery, in the event of system frequency deviation, in underfrequency only. This control function will only be used to handle occasional significant frequency variations, but it must remain in service continuously (unless otherwise indicated by the Transmission Provider). The inertial response must offer the following characteristics:

**a supprimé:** that limits the frequency drop after a major loss of generation on the system

- Activated at a given frequency threshold to order overproduction. The contribution may be full or proportional to the frequency deviation.
- Provide an adjustable dead band from -0.1 Hz to -1.0 Hz with respect to nominal frequency (60 Hz).
- Order an active power overproduction equal to at least 6% of rated power of each wind generator in service.
- Be operational for every wind generator in service whenever their generation level reaches more than 25% of the rated power.
- Provide a maximum overproduction duration of at least 9 s (from the start of power ramp up to the start of power ramp down).
- Limit rise time to reach maximum overproduction in less than 1.5 s.

**a supprimé:** system

**a supprimé:** For disturbances that bring underfrequency (<60.0 Hz) conditions, t

**a supprimé:** system used to comply with this requirement must assure system performance levels that the

**a supprimé:** indicated below may provide

**a supprimé:** full

**a supprimé:** or to order overproduction proportional

**a supprimé:** to

**a supprimé:** maximum momentary real

**a déplacé (et inséré) [2]**

**a supprimé:** approximately

**a supprimé:** and more

**a supprimé:** to

**a supprimé:** or less

**a supprimé:** Decision

**a supprimé:**

[Technical Requirements for the Connection of Generating Stations to the Hydro-Québec Transmission System](#)

- Limit ~~active~~ power decrease during energy recovery (if needed) ~~to a minimum, without exceeding~~ 20% of ~~the active power output at the start of the disturbance~~.
- ~~Be able to operate repeatedly with a 2 min delay after the end of the recovery period following the previous operation.~~

Wind *generating station* performance takes precedence over individual wind generator performance. The power producer must demonstrate the operation and performance of the inertial response system design, [particularly](#) based on tests performed on actual wind generators.

The *Transmission Provider* may also consider any other solution that would allow it to reach the same performance objectives with regards to underfrequency control.

## 12.5 Protection systems

Systems protecting power producer *facilities* must be selective enough to avoid any inadvertent *tripping* when *disturbances* occur. More specifically, no protection or control system must cause, directly or indirectly, ~~tripping of generating units or compensation equipment~~ for the voltage and frequency deviations given in sections 12.2.1, 12.2.2 and 12.2.3. ~~Generating unit~~ protection systems must take into account, in particular, voltage variations associated with [impedance and susceptance of the collector system](#) and [with the transformation ratio of generating unit](#) transformers, since requirements described in sections 12.2.1 and 12.2.2 concern the high-voltage side of the switchyard.

### 12.5.1 Voltage protection

Voltage protection must include both an undervoltage function and an overvoltage function.

Voltage protection settings must comply with steady-state voltage ranges given in section 6.1, as well as post-*disturbance* voltage ~~thresholds and their minimum duration~~ given in [tables 8 and 9 of sections 12.2.1 and 12.2.2](#). ~~These settings must take into account the voltage difference resulting from the presence of a collector system, the step-up transformer and, where applicable, a tap changer~~. Referring to [Table 9](#), for instance, an overvoltage protection with an operating threshold set ~~at a voltage of between 1.15 and 1.20 p.u.~~ must have a minimum time-lag of 30 s.

[If the protection functions used take into account a dead band between the pick-up threshold and the resetting of its timer, the setting used must take this dead band into account so as not to trip in the event of a disturbance briefly exceeding the pick-up threshold without dropping below the timer threshold.](#)

[It is allowable to use undervoltage and overvoltage protections based on RMS rather than on positive sequence to comply with voltage thresholds, provided that the tripping associated with each threshold can only occur when the undervoltage or overvoltage is present on all three phases simultaneously.](#)

Voltage protection must be coordinated with other existing protection systems and initiate *tripping* of the *generating station*, when required, to prevent it from operating under unacceptable voltage conditions.

It is not necessary to have settings for each of the values given in [Table 9](#). [However, some thresholds may be specified in the complementary technical requirements in order to ensure generating station tripping for certain disturbances and following prolonged power loss.](#)

**a supprimé:** Technical Requirements for the Connection of Generating Stations to the Hydro-Québec Transmission System

**a supprimé:** real

**a supprimé:** to approximately

**a supprimé:** rated power

**a supprimé:** produced

**a déplacé vers le haut [2]:** Be operational for every wind generator in service whenever their generation level reaches approximately 25% and more of the rated power;

**a supprimé:** ~~<#>Overfrequency control¶~~  
In order to handle overfrequency *disturbances* (>60.0 Hz), every wind generator within a *wind generating station* must be equipped with a frequency control system with a permanent droop (sigma) adjustable over a range of at least 0 to 5% and a dead band adjustable between 0 and 0.5 Hz.¶  
The power producer must apply the frequency regulation system settings given by the *Transmission provider*.¶  
Requirements regarding frequency control also apply to a *wind generating station* connected to the distribution system, to *facilities* of a municipal system or of the SJBR electricity cooperative.¶

**a supprimé:** wind generator

**a supprimé:** *Wind generator*

**a supprimé:** step-up

**a supprimé:** ranges

**a supprimé:** , for the durations shown in Figure 6 and those

**a supprimé:** Table 8.

**a supprimé:** in the voltage range (

**a supprimé:** < V ≤

**a supprimé:** )

**a supprimé:** wind

**a supprimé:** 8

**a supprimé:** Decision

**a supprimé:**

## 12.5.2 Frequency protection

Frequency protection must include both an underfrequency function and an overfrequency function. Protection settings must in no instance interfere with the measures implemented by the *Transmission Provider* to restore system frequency following a *disturbance*.

Frequency protection settings must comply with the steady-state frequency range given in section 6.2, as well as post-*disturbance* frequency ~~thresholds and their~~ minimum duration, given in [Table 10 in section 12.2.3](#). Referring to [Table 10](#), for instance, a frequency protection with an operating threshold set in the frequency range ~~between 58.5 and 59.4 Hz~~ must have a minimum time-lag of 11 minutes. ~~If a frequency relay counting cycles (rather than a time period) is used, the number of cycles must be set based on the higher value of the frequency threshold.~~

These requirements also apply to a *generating station using SERMOs* connected to the distribution system, to *facilities* of a municipal system or of the SJBR electricity cooperative.

The power producer may use more sensitive underfrequency protection settings provided it demonstrates to the *Transmission Provider* that automatic load-shedding agreements have been signed with a third party to offset any loss of generation should underfrequency protection trip its *generating station*. Frequency protection must be coordinated with other existing protection systems and initiate *tripping* of the *generating station*, when required, to prevent it from operating under unacceptable frequency conditions.

It is not necessary to have settings for each of the values given in [Table 10](#). ~~However, some thresholds may be specified in the complementary technical requirements in order to ensure generating station tripping for certain disturbances.~~

## 12.6 Data required for real-time Transmission System operation

Every *generating station* must provide the required data in real-time and in a format compatible with the *Transmission Provider's* equipment. Required data is described in [Table 6](#) (section 9.1).

For a wind *generating station*, guidance on communication devices is provided in the document entitled *Requirements Specification – Wind Power Data Acquisition*<sup>17</sup>. [For a photovoltaic solar generating station, indications regarding communication devices are supplied in the document entitled Requirements Specification – Photovoltaic Solar Power Data Acquisition](#)<sup>18</sup>. [For other generation technologies, indications on control devices will be issued as needed.](#) The power producer must provide and install in its switchyard all necessary sensors to transmit the required data to the *Transmission Provider*. Upon request by the *Transmission Provider*, the power producer must also take part in tests two months before its *generating station* is commissioned, or at any other date agreed upon with the *Transmission Provider*. Equipment used by the power producer to transmit the required data to the *Transmission Provider* is subject to the latter's approval.

[Active](#) and reactive power measurement requirements given in [Table 6](#) (section 9.1) also apply to a *generating station using SERMOs* connected to the distribution system, to *facilities* of a municipal system or of the SJBR electricity cooperative.

17 Reference provided for explanatory and information purposes only.

18 See note 17.

**a supprimé:** Technical Requirements for the Connection of Generating Stations to the Hydro-Québec Transmission System

**a supprimé:** ranges, for the

**a supprimé:** s

**a supprimé:** Table 9

**a supprimé:** 9

**a supprimé:** (

**a supprimé:** ≤ F <

**a supprimé:** )

**a supprimé:** wind

**a supprimé:** wind

**a supprimé:** Table 9

**a supprimé:** Table 6

**a supprimé:** wind

**a supprimé:** Real

**a supprimé:** Table 6

**a supprimé:** wind

**a supprimé:** only

**a supprimé:** ve

**a supprimé:** Decision

**a supprimé:**

## 12.7 Technical information to submit to the Transmission Provider to conduct its studies

The power producer must supply data and one or more detailed models of the generating station using SERMOs required to conduct dynamic simulation studies, as specified in Appendix A. The power producer must also supply the necessary information and data for conducting studies of transient electromagnetic phenomena, as specified in Appendix B, by providing an EMTP model.

The power producer must supply a demonstration of the conformity of the dynamic models with the real behavior of the generating station.

## 12.8 Management of active power ramps

The generating station using SERMOs must be designed and built to control its power in accordance with the characteristics of the following ramps:

- During deliberate rises or falls in active power: a controlled ramp-up time adjustable from 2 to 20 minutes for a generating station output variation from 0 MW (stopped) to  $P_{max}$  (maximum output).
- During active power variations during normal operation: a controlled ramp-up at an adjustable rate of 0.1% to 100% of installed capacity per second.

The Transmission Provider will supply parameters to be respected depending on operating conditions.

## 12.9 Generating station shutdown when severe weather conditions are forecast

The generating station using SERMOs must be designed and built to allow gradual shutdown over a period of 1 to 4 hours when forecasted cold temperatures, high winds, freezing rain, rapid clouding-over, heavy snowfall, solar eclipse or any other natural phenomenon or any severe weather conditions require their gradual shutdown.

## 12.10 Stabilizer

The generating station using SERMOs must be designed and built so it can be equipped with a stabilizer.

The generating station connected to the Transmission System must have stable behavior so it can help maintain Transmission System stability and restore voltage and frequency when disturbances occur. Otherwise, the Transmission Provider may require that the power producer facilities be equipped with a stabilizer. The stabilizer will then be designed jointly by the Transmission Provider and the manufacturer. The power producer must apply the settings given by the Transmission Provider.

## 12.11 Limiting active power

Given Transmission System operating constraints and requirements, the Transmission Provider may require that the power producer facilities be equipped with a control system capable of responding to a command to limit active power and other commands.

**a supprimé:** Technical Requirements for the Connection of Generating Stations to the Hydro-Québec Transmission System

**a supprimé:** a

**a supprimé:** wind

**a supprimé:** needed to

**a supprimé:** If the models supplied do not comply with IEEE<sup>19</sup> standards, the power producer must supply compliance tests that demonstrate the models accurately represent the response of the actual wind generating station. Besides the information required in Appendix A, the power producer must submit wind generator oscillation characteristics (e.g., natural frequency and damping) for mechanical or electrical disturbances.

**a supprimé:** also provide a detailed description of the strategies used by the real power, reactive power, voltage and frequency control systems under the operating conditions described in sections 6.1 and 6.2.¶  
Given the diverse and rapidly evolving nature of technology used in wind generating stations, the power producer must submit to the Transmission provider test results demonstrating that the wind generating station in question meets the voltage and frequency requirements described in sections 12.2.1, 12.2.2 and 12.2.3.¶  
The power producer must also provide, in the form of an EMTP model, all information and data required to conduct studies on transient electromagnetic phenomena, as specified in Appendix B

**a supprimé:** Maximum up- and down-ramp rates

**a supprimé:** wind

**a supprimé:** comply with the following maximum ramp rates when up-ramping or voluntary down-ramping output

**a supprimé:** Minimum

**a supprimé:** wind

**a supprimé:** Minimum

**a supprimé:** time

**a supprimé:** power

**a supprimé:** from 2 to 20 minutes for a wind generating station output variation from  $P_{max}$  (maximum output) to 0 MW (stopped)...

**a supprimé:** Wind generator

**a supprimé:** very cold weather or high winds

**a supprimé:** wind

**a supprimé:** or

**a supprimé:** wind

**a supprimé:** wind

**a supprimé:** real

**a supprimé:** real

**a supprimé:** Decision

**a supprimé:**

[Technical Requirements for the Connection of Generating Stations to the Hydro-Québec Transmission System](#)

**a supprimé:** Technical Requirements for the Connection of Generating Stations to the Hydro-Québec Transmission System

## 12.12 Headroom

The power producer can operate its *generating station* temporarily or permanently with headroom, i.e., keeping the active power output below available power. This headroom means that, when requested by a regulation function to inject more active power, an immediate quantity of additional energy is deployed.

For the needs of the *Transmission System*, the *Transmission Provider* may also exceptionally require that headroom be maintained at the *generating station*.

## 12.13 Switchyard step-up transformers

Unless stipulated otherwise at the time of the *interconnection study*, ~~switchyard step-up transformers at *generating stations* using *SERMOs*~~ must be equipped with an on-load tap changer and a voltage regulator that allow the transformer ratio to be adjusted according to voltage conditions on the *Transmission System* over a minimum range of  $\pm 10\%$ . ~~Depending on the generation technology, the characteristics of the generation equipment and the design of the *generating station*, the power producer may also demonstrate that its *generating station* is able to meet the requirements set out in sections 12.2.1, 12.2.2 and 12.3 without the use of an on-load tap changer with voltage regulator for switchyard step-up transformers.~~

**a supprimé:** wind *generating station*

**a supprimé:** ¶  
Following the *Interconnection study*, the *Transmission provider* may also require that the power producer *facilities* be equipped with means of mitigating closing transient *disturbances* during switchyard step-up transformer energizing operations.

## 12.14 Continuous injection of reverse-sequence current

Connection of a *generating station* using *SERMOs* to a *Transmission System* line that is not perfectly transposed may, through the circulation of positive-sequence current ( $I_1$ ), generate steady-state negative-sequence voltage ( $V_2$ ). It may then be necessary to transpose circuit conductors to reduce the  $V_2/V_1$  voltage unbalance, particularly in order to keep the unbalance below the value indicated in section 7.8. Injection of continuous negative-sequence current ( $I_2$ ) based on the amplitude and the angle of the negative-sequence voltage measured at the *inverters* may reduce or eliminate the needs for transposition associated with the *generating station* connection. If such a capacity is proposed and guaranteed by the power producer, the *Transmission Provider* could use it if more advantageous overall. For this purpose, the *generating station's* capacity to inject continuous negative-sequence current must be clearly defined in the technical documentation.

## 12.15 Harmonics

The power producer must obtain from the manufacturer the characteristic representation of its *SERMO* model for each harmonic and interharmonic order, based on the anticipated active and reactive power of the *generating station's inverter* and its control systems. A *SERMO* in the form of a Thévenin (or Norton) circuit in the frequency domain is required to facilitate the emission study. The *SERMO* model must also consider the dissymmetry in the *facility* and in the *Transmission System*, particularly a negative sequence voltage unbalance of 2%. Moreover, if the *SERMO* model values vary in accordance with the power produced by the *SERMO* or in accordance with the rate of voltage unbalance in the *system*, these different values must be supplied for each harmonic and interharmonic order, so as to enable an evaluation of the maximum resulting emission level (resulting from the interaction between the *SERMO* and the collector system) at the *generating station's* point of connection with the Hydro-Québec *Transmission System*.

**a supprimé:** Decision

**a supprimé:**

[Technical Requirements for the Connection of Generating Stations to the Hydro-Québec Transmission System](#)

**a supprimé:** Technical Requirements for the Connection of Generating Stations to the Hydro-Québec Transmission System

## List of mandatory reference documents

#	Title or name	Section	Link to view
1	<i>Technical Requirements for the Connection of Customer Facilities to the Hydro-Québec Transmission System</i>	3., 5.2.2	<a href="http://www.hydroquebec.com/transenergie/fr/commence/raccordement_transport.html">www.hydroquebec.com/transenergie/fr/commence/raccordement_transport.html</a>
2	IEC 60034-1 – Rotating electrical machines	7., 7.8	<a href="http://www.iec.ch">www.iec.ch</a>
3	<a href="#">IEEE P2800 Standard for Interconnection and Interoperability of Inverter-Based Resources Interconnecting with Associated Transmission Systems</a>	7.2.2.3.4 <a href="#">Current injection during ride-through mode</a> 7.2.2.3.5 <a href="#">Performance specifications</a>	<a href="#">Standard under development</a>

The *Transmission Provider* must display on its website a hyperlink pointing to the website of the following organization, where it is possible to obtain copyrighted standards:

- International Electrotechnical Commission
- [Institute of Electrical and Electronics Engineers](#)

**a supprimé:** Decision

**a supprimé:**

a supprimé: Technical Requirements for the Connection of Generating Stations to the Hydro-Québec Transmission System

## Appendix A Technical information required by the Transmission Provider to conduct its studies

### Notes

- The power producer is responsible for the validity of information (data, models and associated parameters) submitted by itself or one of its suppliers to the *Transmission Provider* so that the latter may conduct the studies required to assess the impact of connecting a *generating station* to the *Transmission System*. If the *generating station* does not behave according to the models and parameters submitted, the *Transmission Provider* may, if needed, re-estimate the cost of connecting the *generating station* to the *Transmission System*; the power producer shall assume the cost of any additional studies and *Network Upgrades*.
- [As well as the technical information required to conduct studies that is set out in this appendix, the Transmission Provider may require additional information, particularly technical characteristics concerning a specific generation technology or explanatory documentation on control strategies for generation equipment.](#)
- As a member of various bodies responsible for power system reliability [Northeast Power Coordinating Council, Inc. ("NPCC"), [North American Electric Reliability Corporation \("NERC"\)](#)], the *Transmission Provider* may be asked to share with its counterparts information collected during projects covered by a connection agreement between the power producer and itself.

a supprimé: Northern

### 1 Scheduled commissioning date

### 2 Location diagram for power producer facilities

### 3 General information on power producer facilities

- Type of generation (e.g., hydraulic, thermal, wind, photovoltaic solar, energy storage)
- Installed capacity, anticipated capacity at annual peak load and projected ultimate capacity
- [Number of generating units](#)
- [Daily, monthly and annual profiles of maximum expected output](#)
- [Generating station capacity factor and average monthly energy values \(Gwh\) for a typical year](#)
- [Description of items of storage equipment, their power \(MW, MVA\) and energy \(MWh\) dimensions and discharge and charge rates](#)

a supprimé: or

### 4 Power producer equipment characteristics

(Resistance and reactance in p.u. based on equipment MVA)

- *Synchronous generators*:
  - Type (round rotor/salient pole)
  - Generator speed in RPM
  - Damper windings (connection method)
  - Design ambient temperature (°C)
  - Temperature rise at rated power (°C)
  - Coolant temperature (°C)

a supprimé: Decision

a supprimé:



[Technical Requirements  
for the Connection of Generating Stations to the Hydro-Québec Transmission System](#)

**a supprimé:** Technical Requirements  
for the Connection of Generating Stations to the  
Hydro-Québec Transmission System

- Rated power and voltage
- Rated power factor in over-excited and under-excited modes
- Unsaturated direct-axis synchronous reactance ( $X_d$ )
- Unsaturated quadrature-axis synchronous reactance ( $X_{qi}$ )
- Direct-axis transient reactance – unsaturated ( $X'_{di}$ ) and saturated ( $X'_{dv}$ )
- Quadrature-axis transient reactance – unsaturated ( $X'_{qi}$ ) and saturated ( $X'_{qv}$ )
- Direct-axis subtransient reactance – unsaturated ( $X''_{di}$ ) and saturated ( $X''_{dv}$ )
- Quadrature-axis subtransient reactance – unsaturated ( $X''_{qi}$ ) and saturated ( $X''_{qv}$ )
- Positive-sequence leakage reactance ( $X_l$ )
- Negative-sequence reactance ( $X_2$ )
- Time constants  $T'_{do}$  (and corresponding temperature in °C),  $T'_{qo}$ ,  $T''_{do}$  and  $T''_{qo}$
- Armature resistance, by phase ( $R_a$ ) and corresponding temperature in °C
- Stator forward resistance ( $R_1$ ) at 60 Hz and corresponding temperature in °C
- [Field resistance and associated temperature](#)
- Reference generator field current ( $I_{fg}$ ) corresponding to rated no-load voltage on straight-line (air gap) portion of generator curve
- Saturation curve of generators
- Saturation coefficients  $S_{gu}$  and  $S_{g1}$
- Inertia constant H in kW/KVA (for each *generating unit*, with and without turbine)
- *Asynchronous generators:*
  - Design ambient temperature (°C)
  - Temperature rise at rated power (°C)
  - Coolant temperature (if applicable)
  - Rated power and voltage
  - Power factor at 100%, 75% and 50% of rated power
  - Stator leakage reactance ( $X_s$ )
  - Stator resistance ( $R_s$ )
  - Rotor leakage reactance ( $X_r$ )
  - Rotor resistance ( $R_r$ )
  - Magnetizing reactance ( $X_m$ )
  - Locked rotor reactance ( $X_{rb}$ )
  - Open-circuit reactance ( $X_o$ )
  - Time constant  $T'_{do}$
  - Inertia constant H (for each *generating unit*)
  - Torque-slip curve

**a supprimé:** Decision

**a supprimé:**

Technical Requirements for the Connection of Generating Stations to the Hydro-Québec Transmission System

- Steady-state slip
- Generating stations using SERMOs:
  - equipment number, type, models and manufacturers
  - nominal characteristics (kV, MW, MVA, etc.) of inverters
  - equipment reactive power capacity curves
    - for different ambient temperatures (e.g., -35°C -20°C, 0°C, 30°C, 40°C)
    - for voltages ranging from 0.9 p.u. to 1.10 p.u.
  - equipment low-voltage ride through (LVRT) and high-voltage ride through (HVRT) capacities
  - generating station short-circuit current contribution for various fault types (three-phase, two-phase, single-phase)
    - amplitude and angle of positive-sequence and negative-sequence currents depending on time during and after the fault, at different voltage levels
- Characteristics of filters associated with the generating unit when the inverter is on standby
- Transient subsynchronous resonance (SSR) and subsynchronous control interaction (SSCI) phenomena
  - subsynchronous impedance
  - presence or absence of an SSCI phenomena damping system
  - mass, elasticity and damping parameters of mechanical components
- Transformers (all transformers of the generating station):
  - Number
  - Rated capacity and voltage
  - Power and corresponding cooling method
  - Positive- and zero-sequence impedances (and the power base used)
  - Winding resistance
  - Neutral inductance/resistance current impedance and capacity (if present)
  - Coupling (i.e., winding connection)
  - Number of taps and regulation range
  - Exciting current (at 80%–160% of rated voltage: the current can be measured, calculated or simulated)
  - Fixed tap changers
    - number of taps, gap between taps and operating tap
  - On-load tap changers (OLTC)
    - number of taps and gap between taps
    - side of transformer where regulation is performed and regulation range
    - parameters associated with tap change time-lags

**a supprimé:** Technical Requirements for the Connection of Generating Stations to the Hydro-Québec Transmission System

**a supprimé:** <#>Voltage regulator, excitation system and stabilizer, based on guidance provided in the following documents:¶  
Detailed model and associated parameters, referring to standard IEEE model (IEEE Standard 421.5, *IEEE Recommended Practice for Excitation System Models for Power System Stability Studies*<sup>20</sup>), or, if no IEEE model is available.¶  
Model that the *Transmission provider* can use in its dynamic simulation studies with Siemens PTI's Power System Simulator (PSS/E) software, along with associated parameters¶  
Turbine and speed governor, based on guidance provided in the following documents:¶  
Detailed model and associated parameters, referring to standard IEEE model: ¶  
("Dynamic Models for Steam and Hydro Turbines in Power System Studies", *IEEE Transactions on Power Apparatus and Systems*, 1973, vol. PAS-92, pp. 1904-1915<sup>21</sup>);¶  
"Hydraulic Turbine and Turbine Control Models for System Dynamic Studies", *IEEE Transactions on Power Systems*, February 1992, vol. 7, No. 1, pp. 167-179<sup>22</sup>);¶  
"Dynamic Models for Combined Cycle Plants in Power System Studies", *IEEE Transactions on Power Systems*, August 1994, vol. 9, No. 3, pp. 1698-1706<sup>23</sup>); or if no IEEE model is available.¶  
Model that the *Transmission provider* can use in its dynamic simulation studies with Siemens PTI's Power System Simulator (PSS/E) software, along with associated parameters¶  
*Wind g*

**a supprimé:** Detailed model and associated parameters, referring to standard IEEE model or, if no IEEE standard model is available.¶  
Full model that the *Transmission provider* can use in its dynamic simulation studies with Siemens PTI's Power System Simulator (PSS/E) software. The power producer must also provide relevant technical documentation, block diagrams, data and parameters. The model must allow all *generating station* wind generators to be represented as a single wind generator and must be functional over its entire range of real and reactive power. The wind *generating station* model must contain a detailed model of any rotating machinery, including a multimass model of the rotor and blades. It must be functional with a time step exceeding 4 ms. ...

**a déplacé vers le bas [3]:** If models provided by the power producer are not IEEE standard models, the power producer must commit to updating them for the entire period during which the equipment in question will remain in service on the system. In particular, updates may be required whenever the equipment undergoes a hardware or software change, or as the Siemens PTI's Power System Simulator (PSS/E) software evolves.

**a supprimé:** Step-up t

**a supprimé:** (when supplied by the power producer):

**a supprimé:** 15

**a supprimé:** Tap changer parameters (if applicable)

**a supprimé:** Decision

**a supprimé:**

Technical Requirements for the Connection of Generating Stations to the Hydro-Québec Transmission System

**a supprimé:** Technical Requirements for the Connection of Generating Stations to the Hydro-Québec Transmission System

• Generating station collector system

- impedance (Resistance – R, Reactance – X, Susceptance – B)
  - for detailed configuration (by circuit)
  - for simplified configuration (equivalent depending on number of step-up transformers)

• Circuit breakers:

- Main characteristics in voltage and current
- Insulation levels
- Interrupting capacity
- X/R ratio
- presence of preinsertion resistor, impedance, guaranteed and average preinsertion duration
- single-pole/three-pole command
- type of controlled closing device (if present)
- SF6/gas mixture ratio
- description of action taken on low SF6 pressure: single-phase/three-phase locking, automatic closing or disabled operation

• Shunt capacitor banks or filters:

- Power
- Filtered harmonics and layout of RLC components
- *Closing* strategy

• Surge arresters on high-voltage side (if present):

- Type
- Rated characteristics
- Protection characteristics

**5 Single-line diagram of facility planned by the power producer**

Diagram showing power transformers, switchgear position and operating mode (NO/NC), positions of instrument transformers, surge arresters and circuit breakers, as well as the interlocks of disconnect switches and circuit breakers in the high-voltage section (line, busbar, transformer)

**a supprimé:** as well as

**a supprimé:** .

Protection diagram showing the high-voltage section (line, busbar, transformer)

**a supprimé:** A preliminary control and p

**6 Dynamic modeling with Siemens PTI PSSE/E software**

• To conduct its studies of the system's dynamic behavior, the Transmission Provider uses Power System Simulator PSS/E software from Siemens PTI. All dynamic models transmitted by the power producer must be compatible with the current version of this software. Except in case of an agreement between the Transmission Provider and the power producer, dynamic models representing the behavior of generation equipment must be included in the PSS/E library.

**a supprimé:** Decision

**a supprimé:**

Technical Requirements  
for the Connection of Generating Stations to the Hydro-Québec Transmission System.

- Synchronous generators and asynchronous generators connected directly to the system:
  - The power producer must indicate to the Transmission Provider which dynamic models are included in the PSS/E library and supply the associated validated parameters for all generation equipment at the generating station:
    - alternator or generator
    - voltage regulator (if applicable)
    - excitation system (if applicable)
    - turbines and speed governors (if applicable)
    - power stabilizer (if applicable)
- Generating stations using SERMOs:
  - The power producer must indicate to the Transmission Provider what dynamic models are included in the PSS/E library and supply the associated validated parameters for all components, all functions and all controls of the generating station. The models identified by the power producer must faithfully represent the generating station's dynamic behavior.
  - If an agreement is concluded with the Transmission Provider, the power producer may transmit full "user" models that the Transmission Provider can use in its dynamic behavior studies with the current version of Power System Simulator (PSS/E) from Siemens PTI. The modeling must be able to represent each of the generating station's various generation sources (technologies and types) as a single aggregate item of generation equipment and must be able to function throughout its entire active and reactive power range. Any model must function with all time steps above 4.167 ms. The modeling of the generating station must include all relevant components for simulation, i.e., models for wind generators, solar panels, storage systems, etc., including their controls and controls at the generating station level. The modeling of the generating station must include, if applicable, details of any rotating machinery, including a multimass model of the rotor and wind turbine. Documentation on the modeling must cover the following points:
    - The short-circuit ratio (SCR) range for which use of the models has been validated
    - Initialization and conduct of simulations
    - A list and description of the model's parameters (default, minimum and maximum values, and units)
    - Block diagrams explaining the model's functionalities
      - i. detailed description of strategies for control of voltage (reactive power) and frequency (active power, including primary frequency regulation)
      - ii. operating modes (steady-state and during faults)
        - with activation times and return to steady-state modes (ramps)
        - active and reactive power priority modes, if applicable
    - Explanations for conducting the following simulations:
      - i. change the reference voltage (or reactive power, or power factor)
      - ii. change the reference frequency
      - iii. change the reference active power

**a supprimé:** Technical Requirements for the Connection of Generating Stations to the Hydro-Québec Transmission System

**a supprimé:** Annual generation pattern projected by the power producer  
Capacity factor of generating station and average monthly generation in terms of energy (GWh) and power for a typical year....

**a supprimé:** Decision

**a supprimé:**

Technical Requirements for the Connection of Generating Stations to the Hydro-Québec Transmission System.

iv. change the parameters for voltage and frequency regulation settings (i.e., gains, dead bands and droop)

- In its explanations, use the same parameter names as in the parameter description record for the PSS/E model

– If voltage regulation in the *generating station* is achieved using additional compensation equipment in the switchyard, the power producer must provide a detailed model of that equipment based on a standard IEEE model, as well as associated parameters that the *Transmission Provider* can use in its dynamic simulation studies with the current version of Siemens PTI's Power System Simulator (PSS/E) software.

– If the models provided by the power producer are not included in the PSS/E library, the power producer must commit to updating them within 90 days of a request from the *Transmission Provider*, for the entire period during which the equipment in question will remain in service on the system. If the models are not accessible to the *Transmission Provider*, the source code used to compile the DLL (dynamic link library) and the passwords for encryption must be filed with a third party in order to ensure that the information is available following a request from the *Transmission Provider*. In particular, updates of the models may be required whenever the equipment undergoes a hardware or software change.

**a supprimé:** Technical Requirements for the Connection of Generating Stations to the Hydro-Québec Transmission System

**a supprimé:** wind

**a supprimé:** . If no IEEE model is available, the power producer must provide a model

**a supprimé:** , along with associated parameters.

**a déplacé (et inséré) [3]**

**a supprimé:** IEEE standard models,

**a supprimé:** , or as the Siemens PTI's Power System Simulator (PSS/E) software evolves

**a supprimé:** Decision

**a supprimé:**

## Appendix B Information required by the Transmission Provider for modeling of generating stations using SERMOs with EMTP software

Information described in this section is necessary to allow the *Transmission Provider* to conduct studies (e.g., *Facilities Study*) for a broad frequency spectrum (e.g., harmonic study, stability of control systems, protections, etc.) essential for a detailed analysis of how the *Transmission System* will behave once the *generating station using SERMOs* (e.g., wind or photovoltaic solar generating station, energy storage, hybrid systems) is connected. The power producer must therefore provide a detailed model of the transient, temporary and steady-state response of the following main components of the *generating station*: generation equipment (e.g., wind, photovoltaic solar panels, energy storage) and related power equipment using inverters or control systems (e.g., SVC and STATCOM), as well as *generating station control systems* (e.g., voltage regulator at the connection point). The present requirements are issued for projects operating connected to Hydro-Québec's integrated *Transmission System*. If the chosen project is planned for operation in islanded mode, additional modeling requirements could be issued.

For *generating stations using SERMOs*, the detailed model must meet the following requirements:

- The model must be compatible with EMTP software with a calculation step range clearly defined in its documentation and including the value of 10  $\mu$ s. It must be able to be solved using Trapezoidal and Backward Euler calculation algorithms. The model must be initialized from power flow and allow the study of transient phenomena after 1 second of simulation. The model must be usable without installation, that is using only files stored in the directory containing the EMPTP network file (fichier.ecf) and subdirectories and must not use an absolute file path. It must be possible to simulate several instances of the same model in the same simulation simultaneously.
- The equipment of a *generating station using SERMOs* can be represented by a separate model for each type of equipment. However, to simplify and lighten simulations, aggregation of equipment of the same type must be possible (e.g., *generating station* modeled by a model representing all wind generators and a model representing the STATCOM used as compensation equipment). The model supplied must be able to function across the equipment's entire active and reactive power range, including shutdown/standby mode in which certain equipment, such as the transformer and filters, may be energized.

a supprimé: Technical Requirements for the Connection of Generating Stations to the Hydro-Québec Transmission System

a supprimé: wind generating station

a supprimé: using

a supprimé: -RV

a supprimé: transient-state

a supprimé: the wind

a supprimé: , a required element of the facilities study

a supprimé: wind

a supprimé: such as converters equipped with controls

a supprimé: wind

a supprimé: -RV

a supprimé: Decision

a supprimé:

Technical Requirements for the Connection of Generating Stations to the Hydro-Québec Transmission System.

- The model components must be fully user-accessible, i.e., unlocked. An agreement may however be reached with the *Transmission Provider* in order to encrypt the model or use a DLL model (compiled code which must include all libraries and references used within the DLL). The power producer must commit to updating it for the entire period during which the equipment in question will remain in service on the system. In particular, updates are required whenever the generating station undergoes a hardware or software change, or as the EMTP software evolves (e.g., if recompilation of the model is required). If the model is not accessible to the Transmission Provider, the source code used to compile the DLL and the passwords used for encryption must be filed with a third party to ensure that the information will be available following a request from the Transmission Provider. The *Transmission provider* may require a model capable of running on the Hydro-Québec real-time simulator Hypersim. Neither the power producer nor its manufacturer are required to design and deliver such a model. However, since the *Transmission Provider* will elaborate this model based on data taken from the EMTP model, locked portions of the EMTP model may be made accessible to the Transmission Provider. For instance, it is possible to use a DLL designed for EMTP to model the controls of a machine (or a source) and run it as-is in the Hypersim environment provided the power equipment controlled by this DLL and modeled in EMTP is accessible to the Transmission Provider so as to allow their modeling in Hypersim.
- The model supplied must be accompanied by detailed technical documentation, including modeling assumptions, a functional diagram of the elements and functions modeled, descriptions of components and control systems modeled, and results of model validation tests to ensure conformity between the model and the equipment represented in the allowable calculation step range. Limits to using the model must be clearly stated.
- It must be possible to modify in the model the various settings and parameters that the Transmission Provider or the power producer can modify (e.g., voltage regulator gain, control modes, etc.) and must use the data-entry "mask" (or "script black box"). The documentation must explain the effect of such settings and indicate their limits. The robustness of the system (equivalent SCR at the connection point) required for the model to function properly must be indicated in the documentation as well as the manner of calculating this robustness if other inverters, shunt capacitor banks and series compensation are present.
- The model supplied must include an accurate representation of the behavior of the equipment modeled during and after a disturbance (current, voltage and dynamic behavior), during interactions with series compensation (ferroresonance or subsynchronous interactions of SSCI control systems), during interactions with other control systems or following the formation of an island, including the effect of active harmonic filters, physical limits, nonlinearities and the effect of protection or control systems that could affect the behavior of the equipment or the generating station. Blocking/restarting of electronic power components, conduction of antiparallel diodes, PLL (phase lock loop) dynamics, and the operation of protections and functions such as crowbar and DC Chopper must be represented, as well as the effect of all voltage regulators having a time constant of less than 2 seconds, including voltage and power factor regulation systems at the connection point.
- Modeling particularities depending on the equipment type represented:
  - The wind generator model must contain a detailed model of any rotating machinery, including a multimass model of the rotor and blades. Wind turbines must be represented by an equivalent allowing operation in constant wind and taking into account the variability of its mechanical power output during disturbances, which may include the effect of any variable pitch.

**a supprimé:** Technical Requirements for the Connection of Generating Stations to the Hydro-Québec Transmission System

**a supprimé:** M

**a supprimé:** (compiled)

**a supprimé:** However, if the model is not user-accessible, t

**a supprimé:** may be

**a supprimé:** equipment

**a supprimé:** Furthermore,

**a supprimé:** t

**a supprimé:** it may need to gain access to

**a supprimé:** be

**a supprimé:** it

**a supprimé:** on the actual equipment

**a supprimé:** wind generating station

**a supprimé:** that takes into account the variability of its power output, including

**a supprimé:** Decision

**a supprimé:**

Technical Requirements  
for the Connection of Generating Stations to the Hydro-Québec Transmission System.

- The photovoltaic converter model must include a detailed model of photovoltaic solar panels and associated controls, with a representation of its actual operating limits (e.g., V-I and P-V curve). The PV source must be represented by an equivalent that allows operation across its entire power range, taking into account constant solar radiation. Control strategies that affect system response during *disturbances* must be represented, particularly the algorithm for monitoring the solar panels' maximum operating point and current limiters.
- The model of the battery energy storage system must include a detailed model of the battery and its associated controls, with a representation of its actual operating limits and various modes of operation (e.g., during charging, discharging, voltage regulation without real-power injection). Control strategies that affect system response during *disturbances* must be represented, particularly controls associated with continuous currents and voltages.
- The compensator model (STATCOM) must include, if applicable, the elements switched and the *closing* method used, as well as the time-lags between successive switching events and the residual voltage that may be present in capacitors.
- Other technologies: since technologies are constantly evolving, specific modeling requirements will be issued if the equipment used are not indicated in this appendix (e.g., an inertial storage system or a fuel cell) or if the evolution of existing technologies and the discovery of new phenomena necessitate additional modeling requirements to enable the *Transmission Provider* to conduct its studies.
- The model must adequately simulate harmonics (including subharmonics and interharmonics) produced by the *generating station* using *SERMOs* over its equipment's entire range of *active* and reactive power. The model must also allow adequate representation of the *generating station's* interactions with harmonics (including subharmonics and interharmonics) present on the *system*.
- The EMTP model must be completed and submitted to the *Transmission Provider* no later than six months after the winning project(s) are announced under a call for tenders by Hydro-Québec in its electricity distribution activities. For projects carried out without tendering, the model must be submitted to the *Transmission Provider* at the signing of the *interconnection study* agreement pursuant to the *Hydro-Québec Open Access Transmission Tariff*. The design of the EMTP model provided must meet Hydro-Québec's requirements and must be able to be used satisfactorily for studies of the *Transmission Provider's* system. This means that the delivery dates indicated above are for a tested, validated functional model rather than a model in development.

**a supprimé:** Technical Requirements for the Connection of Generating Stations to the Hydro-Québec Transmission System

**a supprimé:** <#>The model must be functional across the equipment's entire range of real and reactive power, and must be designed to simulate all wind generators of the same type using a single model of higher capacity.¶  
If the equipment modeled relies on power electronics, the model must provide a detailed representation of converters, including controllers and the physical limitations of components.¶  
If the wind *generating station* or its equipment contain capacitor banks or filters, both these components and their control logic must be represented. The control logic must also be documented.¶

**a supprimé:** <#>wind

**a supprimé:** <#>real

**a supprimé:** <#>The model must provide an accurate representation of the behavior of the generation equipment and related power equipment during and after a *disturbance* (current, voltage and dynamic response), including the effect of control and protection systems on the response of the equipment or wind farm. Blocking of power electronic components or operation of crowbar protection must be represented in addition to the effect of all voltage regulators with a time constant of less than 2 s, including the voltage and power factor regulation systems at the connection point.¶

**a supprimé:** <#>Distribution

**a supprimé:** Decision

**a supprimé:**



a supprimé: Technical Requirements for the Connection of Generating Stations to the Hydro-Québec Transmission System

## Appendix C Information to be included in [the](#) power producer facility protection study

The power producer must submit to the *Transmission Provider* a study on protection systems for its *facilities*. The study, signed by an engineer, must include the information listed in this Appendix.

### Section 1: Introduction

- Brief description of site, project and Hydro-Québec *Transmission System*
- Distinctive project features (e.g., added protections, specific instructions)
- Possible future expansion projects (adding capacity)

### Section 2: Characteristics of power producer *facilities*

- Single-line diagram of power producer *facilities*
- Electrical characteristics of generating equipment and protection systems:
  - ~~Synchronous generators~~, asynchronous generators [or inverters](#)
  - Converters (if applicable)
  - Transformers
  - Circuit breakers
  - Grounding transformer or neutral reactor impedance
  - Protective relays
  - Instrument transformers for protection systems
  - Excitation system

a supprimé: or

### Section 3: Fault study

- Fault calculations (three-phase, two-phase, two-phase-to-ground, and phase-to-ground faults, with and without a fault impedance; for high-impedance faults, the fault resistance used must be  $R_f = 10 \Omega$  and  $Z_0 = 3 R_f = 30 \Omega$ ):
  - on the high-voltage busbar of the *generating station*
  - on the low-voltage busbar of the *generating station*
  - on the busbar(s) of associated Hydro-Québec substation(s)
  - on the system side of tie breaker (if it is far from the *generating station*)

Fault calculations must factor in:

- *Transmission System* contribution and minimum and maximum *generating station* contributions
- Contribution of the *generating station* alone

a supprimé: Decision

a supprimé:

**a supprimé:** Technical Requirements for the Connection of Generating Stations to the Hydro-Québec Transmission System

#### Section 4: Relay settings and coordination curves

- Table showing proposed protective relay settings for protecting the *Transmission System* and their operation time for faults studied
- Protection coordination times or curves
- Control (or logic) and protection diagrams

**a supprimé:** Decision

**a supprimé:**

a supprimé: Technical Requirements  
for the Connection of Generating Stations to the  
Hydro-Québec Transmission System

## Appendix D General Reference Electrical Characteristics ("CEGR") – Static excitation system for salient-pole and round-rotor generators

### D.1 Description

This document defines performance requirements applicable to static excitation systems for salient-pole generators and round-rotor generators. The excitation system must be equipped with delta-omega multiband stabilizer in conformity with the CEGR *Delta-omega multiband stabilizer* described in Appendix E.

### D.2 General Characteristics of the Excitation System

The excitation system type must be static. Figure D.1 shows a simplified diagram of the excitation system.

Figure D.1: Simplified scheme of static excitation system

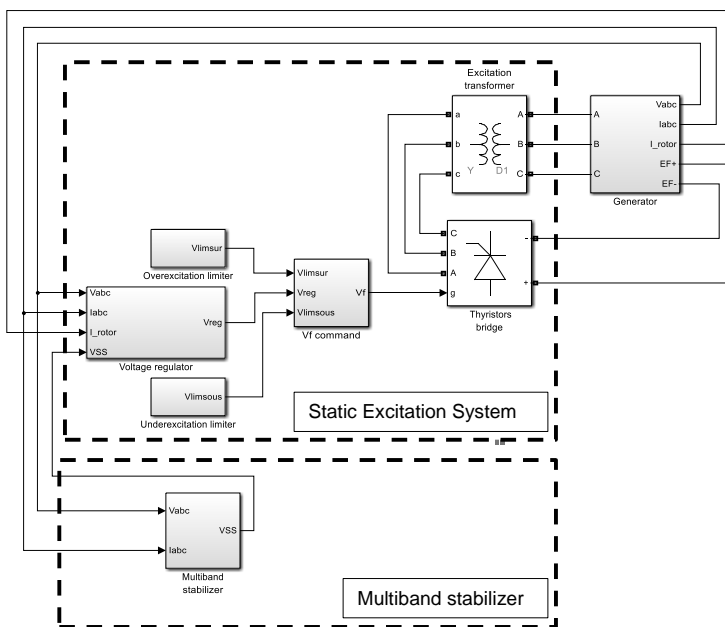

Power must be supplied to three-phase thyristor converter bridges through an excitation transformer connected to the generator terminals. The excitation system must include all the devices required to feed the generator field and must be able to adequately control the generator terminal voltage under all operating conditions.

a supprimé: Decision

a supprimé:

**a supprimé:** Technical Requirements for the Connection of Generating Stations to the Hydro-Québec Transmission System

### Ceiling -voltage

The ceiling voltages of the excitation system must be plus and minus 10 p.u.

The excitation voltage per-unit value is defined as the product of the field current, measured on the air gap line at the nominal generator terminal voltage, by the field winding resistance at 100°C.

### Ceiling current

The ceiling current of the excitation system must be greater than or equal to 1.6 times the nominal current. The excitation system must be capable of delivering the ceiling current for at least 30 seconds for salient pole generators or 15 seconds for round rotor generators. A negative excitation current is not required, but the excitation system must be capable of supplying the de-energization ceiling up to the zero excitation current limit.

### Transmission System voltage and frequency constraints

In addition to normal *generating unit* operating conditions and temporary shut-down or startup conditions, the excitation system must remain in operation under all voltage and frequency conditions (measured at the connection point of the *generating station*) that may occur during *Transmission System disturbances*. The values and minimum times to respect are presented in tables 2, 3 and 4 (see chapter 6).

**a supprimé:** ranges

In these last conditions, the excitation system must be capable of operating at full capacity without *tripping* itself or causing the generator to trip. Over- and underexcitation limiter circuits must therefore be provided; they must take control of the excitation system if needed and force the field current to remain within the limits imposed by an excitation system overload (overexcitation limiter) or within those imposed by a loss of synchronism or generator protections (underexcitation limiter).

## D.3 Voltage Regulator

The open-loop dynamic response of the excitation system must yield an equivalent time constant of 0.02 second. The gain must be continuously adjustable from 10 p.u. to 400 p.u. The voltage regulator must essentially be a proportional controller so as to avoid any modification of the stabilizer transfer function over the entire frequency range covered by the various stabilizer bands. The terminal voltage sensor must be equipped with a filter with an attenuation factor of at least 20 dB at 60 Hz.

The regulator must be equipped with a stabilization signal introduced at the level of the voltage set point and filtered voltage measurement summer (output of voltage measurement sensor and its filter).

A specific (analog or digital) input must be provided to allow the addition of a stabilization (analog or digital) signal generated by a hardware platform other than that included with the currently supplied excitation system. The voltage regulator must give priority to the sampling of this signal at a rate less than 10 ms.

The voltage regulator gain must be automatically modified in case of power outage or stabilizer malfunction, mechanical generator fault or stabilizer disabling while the generator is operated in the voltage regulation mode. The new gain must be adjustable from 10 to 100 p.u.

**a supprimé:** Decision

**a supprimé:**

**a supprimé:** Technical Requirements for the Connection of Generating Stations to the Hydro-Québec Transmission System

## D.4 Limiter Circuits

The excitation system must include overexcitation and underexcitation limiter circuits.

### D.4.1 Overexcitation limiter

During temporary undervoltages, the excitation system must remain in operation in order to gradually return the generator terminal voltage to a value close to its nominal value. An overexcitation limiter circuit must take control of the excitation system and decrease the field current to a value close to its nominal value whenever the maximum heating capacity of the excitation system, as measured using the field current, is exceeded.

The dynamic response of the overexcitation limiter must ensure that transient variations are sufficiently dampened irrespective of voltage regulator settings.

### D.4.2 Underexcitation limiter

During temporary overvoltages, the excitation system must remain in operation in order to gradually return the generator terminal voltage to a value close to its nominal value. When the field current becomes too low, an underexcitation limiter must take control of the excitation system and maintain the generator field current sufficient to avoid loss of synchronism or *tripping* by the field loss protection.

The dynamic response of the underexcitation limiter must ensure that transient variations are sufficiently dampened irrespective of voltage regulator setting.

## D.5 Excitation System Testing

Excitation systems must be subjected to validation and performance tests (see chapter 10) to verify all their characteristics and performance. Furthermore, the tests must allow the block-by-block identification of the transfer functions of all excitation system elements (e.g., amplifiers, time constants, sensor responses, limiters, non-linear elements, auxiliary control loops).

**a supprimé:** Decision

**a supprimé:**

**a supprimé:** Technical Requirements for the Connection of Generating Stations to the Hydro-Québec Transmission System

## Appendix E General Reference Electrical Characteristics (“CEGR”) – Delta-omega multiband stabilizer

### E.1 Description

The purpose of the stabilizer is to improve power swing damping for a generator using excitation system voltage modulation. The stabilization signal is carefully adjusted in both phase and amplitude to provide the desired power swing damping in order to ensure the stability of the Hydro-Québec *Transmission System* and therefore the reliability and continuity of the transmission service.

### E.2 General Characteristics of the Stabilizer

The main functions of the stabilizer are:

- rotor speed synthesis using generator voltage and current signals (Dw synthesis of Figure E.1)
- stabilizer transfer function implementation using a quadruple frequency band structure
- test module to verify the functioning of the stabilizer and the excitation system

The delta-omega multiband stabilizer must be implemented on a digital platform. [a simplified scheme of which](#) is presented in Figure E.1 [below](#).

**a supprimé:** which the

**a supprimé:** following

**a supprimé:** Decision

**a supprimé:**

**a supprimé:** Technical Requirements  
for the Connection of Generating Stations to the  
Hydro-Québec Transmission System

Figure E.1: Simplified scheme of the multiband stabilizer

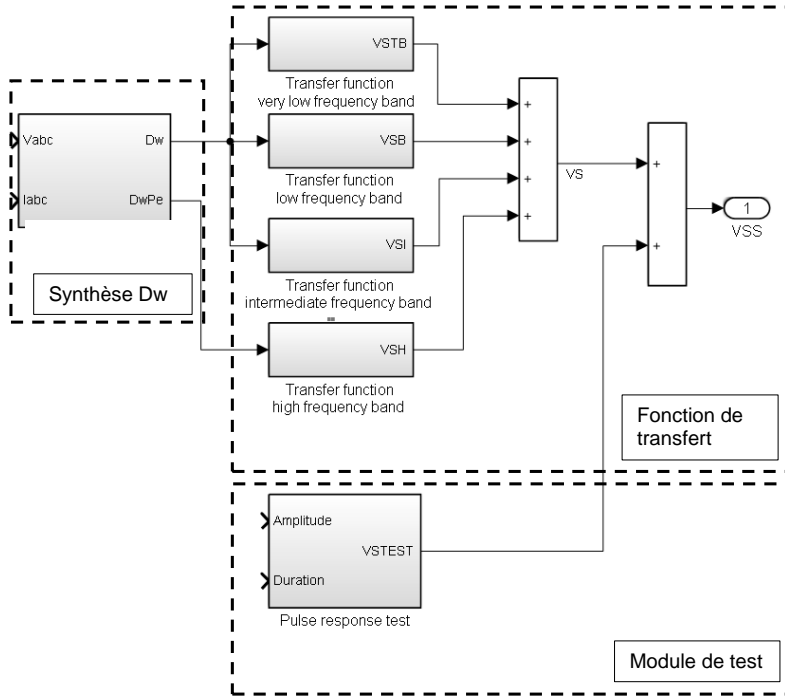

### E.3 Rotor Speed Synthesis

Rotor speed synthesis is calculated using voltage and current measurements at the generator terminals by using two digital sensors, as shown in Figure E.2:

- The first sensor supplies the input signal of the very low, the low and the intermediate frequency bands (Dw TB, B et I)
- The second sensor supplies the input signal of the high frequency band (DwPe)

The dynamic response of the sensors must be equivalent to that of the linear models shown in Figure E.2.

**a supprimé:** Decision

**a supprimé:**

a supprimé: Technical Requirements  
for the Connection of Generating Stations to the  
Hydro-Québec Transmission System

Figure E.2: Rotor Speed synthesis

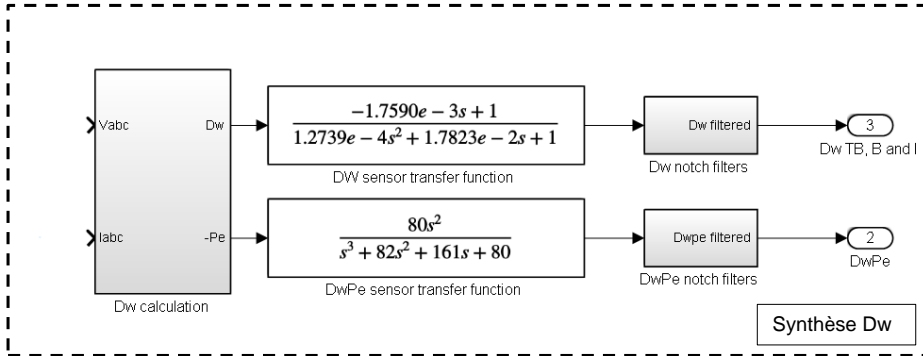

Two notch-type digital filters (Dw and DwPe) arranged in a cascade must be available as needed for turbine-generator applications in order to adequately compensate the effect of torsional modes on speed measurements. For these applications, the notch filters  $N_i(s)$  must be adjustable according to the resonance frequency  $\omega_i$  and the characteristic -3 dB bandwidth  $B_i$  as defined in the equation of the Figure E.3:

Figure E.3: Notch Filter Characteristics

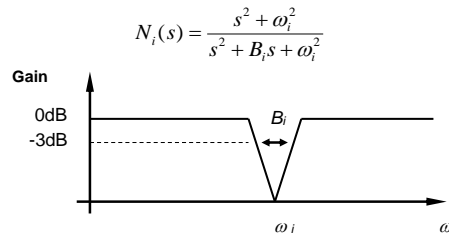

a supprimé: Decision

a supprimé:



a supprimé: Technical Requirements  
for the Connection of Generating Stations to the  
Hydro-Québec Transmission System

## E.4 Stabilizer Transfer Function

### E.4.1 Description

Figure E.4 shows the transfer function of the multiband stabilizer.

Figure E.4: Transfer function of the multiband stabilizer

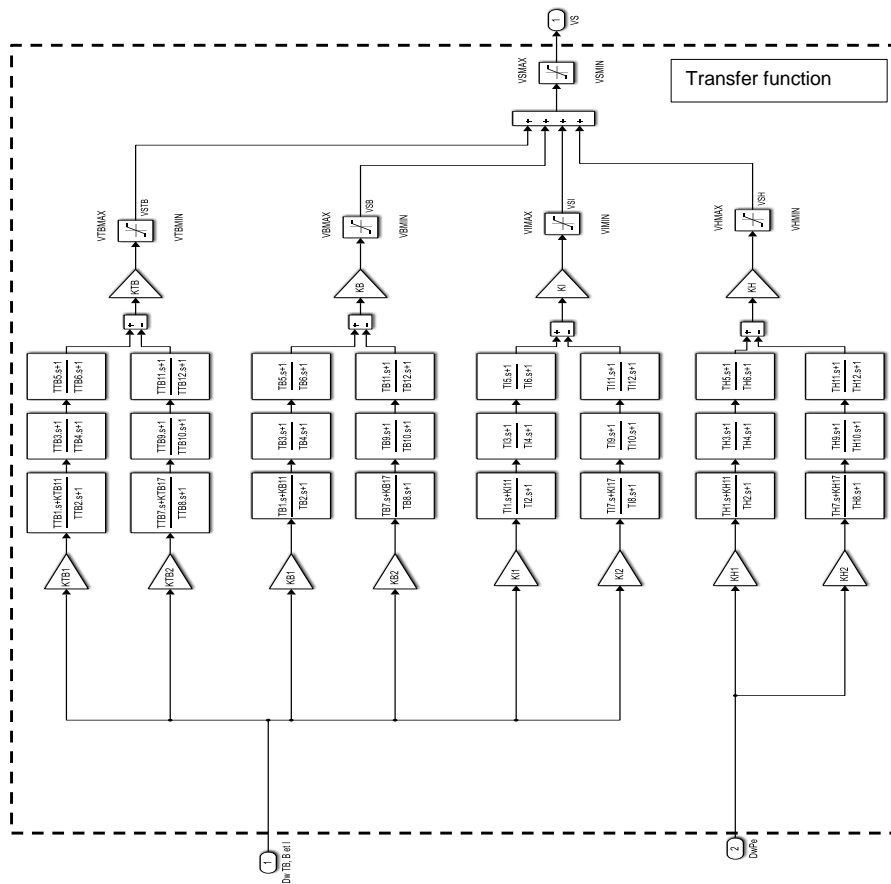

This function must be designed to operate separately over four frequency bands. Each band must have a global gain and a limiter. The transfer function must also include a limiter at the stabilizer output. Each band must comprise two segments configured as a differential filter, each including a gain, a lead-lag or high-pass blocks, as well as two series lead-lag blocks.

a supprimé: Decision

a supprimé:

**a supprimé:** Technical Requirements for the Connection of Generating Stations to the Hydro-Québec Transmission System

The transfer function must comprise two inputs, corresponding to the outputs of the digital speed sensors defined in section E.3 .

- The speed sensor (Dw TB, B and I) matches the entry of the very low, low and intermediate frequency bands.
- The speed sensor (DwPe) matches the entry of the high frequency band.
- The stabilization signal (VS) is the output of the transfer function. This signal is added to the signal of the test module (VSTEST) to give the output signal of the stabilizer (VSS), as shown in Figure E.1. This last signal is connected to the voltage regulator of the excitation system of the generator, as shown in Figure E.1 of the CEGR *Static excitation system for salient pole generators and round rotor generators* described in Appendix D.

#### E.4.2 Setting ranges of gains, time constants and limiters

The gains must be adjustable according to the Table E.1. The gains KTB11, KTB17, KB11, KB17, KI11, KI17, KH11 and KH17 are used in the first block of each transfer function segment to allow the modeling of either a high-pass filter (when set to a value near zero) or a lead-lag filter (when set to a value equal to 1). A zero value for any one of these parameters cancels the output of the corresponding block.

**Table E.1: Setting of gains**

Gains	Setting ranges (pu/pu)
KTB1, KTB2, KTB, KB1, KB2, KB, KI1, KI2, KI, KH1, KH2 et KH	0 to 300
KTB11, KTB17, KB11, KB17, KI11, KI17, KH11 and KH17	0 to 1

The time constants must be adjustable according to the Table E.2.

**Table E.2: Setting of time constants**

Time constants	Setting ranges (s)
TTB1, TTB2, TTB3, TTB4, TTB5, TTB6, TTB7, TTB8, TTB9, TTB10, TTB11 and TTB12	0 to 60
TB1, TB2, TB3, TB4, TB5, TB6, TB7, TB8, TB9, TB10, TB11 and TB12	0 to 30
TI1, TI2, TI3, TI4, TI5, TI6, TI7, TI8, TI9, TI10, TI11 and TI12	0 to 3
TH1, TH2, TH3, TH4, TH5, TH6, TH7, TH8, TH9, TH10, TH11 and TH12	0 to 1

The output of each frequency band and the total output of all four frequency bands shall be also limited using limiters which must be adjustable independently according to Table E.3.

**a supprimé:** Decision

**a supprimé:**

**a supprimé:** Technical Requirements for the Connection of Generating Stations to the Hydro-Québec Transmission System

**Table E.3: Setting of limiters**

Limiters	Setting ranges (pu)
$V_{TBMAX}$ , $V_{BMAX}$ , $V_{IMAX}$ , $V_{HMAX}$ , and $V_{SMAX}$	0 to 1
$V_{TBMIN}$ , $V_{BMIN}$ , $V_{IMIN}$ , $V_{HMIN}$ and $V_{SMIN}$	-1 to 0

The output level of the signal of stabilisation (VS) must be adapted to the various existing excitation systems on which the multiband stabilizer can be connected. This adjustment of the output level must be carried out by a global gain applied to the output of the stabilizer.

## E.5 Control Logic

Some logic functions must command the operation of the stabilizer with the excitation system. Figure E.5 schematizes the following elements of the control logic of the stabilizer:

### Logical inputs

- Local external ON/OFF control with dry contact or human-machine interface (1).
- Remote external ON/OFF control with pulse control (2 and 3 respectively).
- Mechanical fault with dry contact (4).

### Logical outputs

- Gain reduction control of voltage regulator with dry contact (12).
- Stabilizer ON/OFF control state transmitted to annunciator and sequential event recorder with dry contact for each one. A single dry contact is sufficient if the *generating station* is equipped with a *generating station* integrated computer control (SICC) (13).
- Signaling of stabilizer faults transmitted to annunciator and sequential event recorder with one dry contact for each one. A single dry contact is sufficient if the *generating station* is equipped with a SICC (14).
- Logical state Stabilizer active indicating that the stabilizer is enabled (15).

### Internal signals

- Logical state Overspeed gain reduction control generated by the overspeed function (6).
- Synthesized speed in p.u., as calculated by the speed synthesis algorithm. The synthesized speed is used in the calculation of the overspeed function (9).
- Active power (PE) in p.u., as calculated by the speed synthesis algorithm (10).
- Positive sequence current ( $I_{mach}$ ) in p.u., as calculated by the speed synthesis algorithm (11).
- Stabilizer fault generated by stabilizer supervision algorithms (logical state WatchDog\_error and Loss of phase) (7 and 5 respectively).
- Open-loop pulse response test (8).

**a supprimé:** Decision

**a supprimé:**

a supprimé: Technical Requirements  
for the Connection of Generating Stations to the  
Hydro-Québec Transmission System

Figure E.5: Control Logic of the Multiband Stabilizer

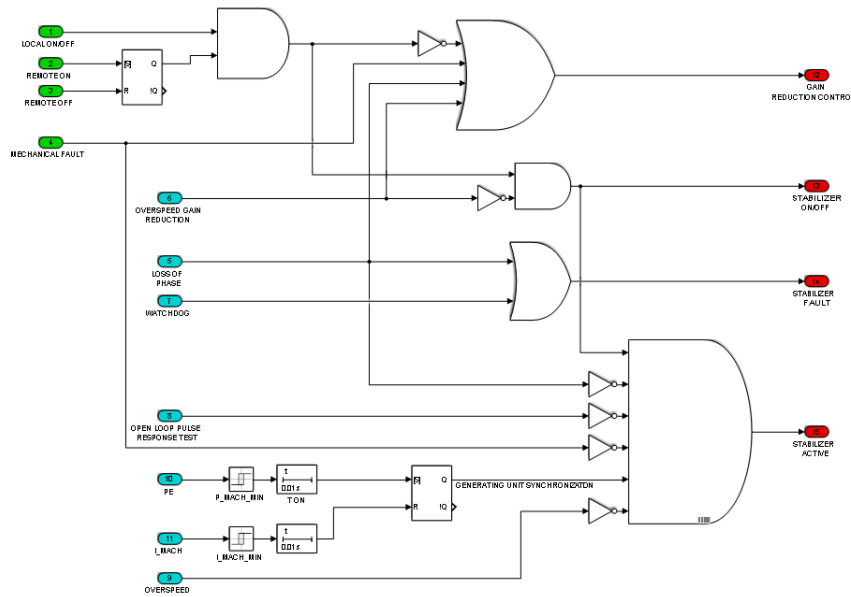

### E.5.1 Local and remote stabilizer control

It must be possible to enable or disable the stabilization signal locally or remotely. Disabling the stabilization signal must also trigger, by means of a dry contact, the reduction of the gain of the generator excitation system voltage regulator to a preset value.

When the stabilizer is disabled locally, remote control enabling or disabling is no longer allowed. Nevertheless, the local disabling function must not prevent the remote control latch from operating. Thus, when the stabilizer is enabled locally, the last operating state stored by the remote control latch must be restored.

### E.5.2 Overspeed

This function is required for hydraulic *generating units*. It disables the stabilizer as soon as the generating unit speed exceeds a threshold, Vitmax, adjustable between 105% and 120% of the nominal speed of the unit in question (logical state Overspeed according to reference 9 in Figure E.5).

This function is designed to limit dynamic overvoltages caused by *generating station* load shedding. This function will be able to discriminate between full generator load rejection conditions and partial generator load rejection conditions with *islanding*. In case of full load rejection, the stabilizer is disabled without any voltage regulator gain reduction before reaching the overfrequency protection trip threshold of the generator. In case of partial load rejection, the stabilizer is disabled while the voltage regulator gain is reduced so as to keep the generator islanded with a sufficient margin of stability (logical state Overspeed gain reduction according to reference 6 in Figure E.5).

a supprimé: Decision

a supprimé:

**a supprimé:** Technical Requirements for the Connection of Generating Stations to the Hydro-Québec Transmission System

### E.5.3 Mechanical fault

The stabilization signal must be disabled when a generator mechanical fault is detected through a dry contact provided on the generator mechanical protection. Disabling the stabilization signal must also trigger, by means of a dry contact, a reduction of the gain of the generator excitation system voltage regulator to a preset value.

### E.5.4 Generator synchronization

The stabilization signal must only be enabled after a delay sufficiently long to allow a balanced state to be reached during generator synchronization. A balanced state is reached if the main generator breaker has been closed in advance and a minimum amount of active power has been generated during an adjustable time interval. Active power is calculated in real-time by the stabilizer (using the speed synthesis algorithm). Once the stabilizer is enabled (logical state Stabilizer active according to reference 15 in Figure E.5), it must stay enabled irrespective of the active power value until it is disabled.

The power detection logical variable depends on the following settings:

- The active power detection logical variable may take the values 1 or 0, depending on whether the minimum power threshold has been exceeded. This threshold ( $P_{mach\_min}$  according to reference 10 in Figure E.5) is adjustable from 0.1 to 0.2 p.u. of the nominal power of the generator.
- The time on delay ( $T_{ON}$  according to reference 10 in Figure E.5) is adjustable from 1 to 10 seconds).

The reset condition of the generator synchronization function is initiated when the main *generating unit* breaker is tripped. The breaker state is detected through a low positive sequence current. The current is calculated in real-time by the stabilizer (using the speed synthesis algorithm). Breaker state detection depends on the following settings:

- The low current detection logical variable may take the values 0 or 1, depending on whether the low current threshold ( $I_{mach\_min}$  according to reference 11 in Figure E.5) has been exceeded after a fixed time on delay set to 2 seconds. This threshold is adjustable from 0.05 to 0.10 p.u. of positive sequence current based on the nominal power of the generator).

### E.5.5 Stabilizer fault

The stabilization signal must be disabled when a stabilizer fault is detected through stabilizer supervision algorithms. Disabling the stabilization signal must also trigger, by means of a dry contact, the reduction of the gain of the generator excitation system voltage regulator to a preset value. Supervision algorithms must at least detect stabilizer faults in the following conditions:

- Detection of an error by the dedicated stabilizer watchdog (Watchdog according to reference 7 in Figure E.5).
- Detection of an error during the loss of one, two or three current phases or voltage phases (Loss of phase according to reference 5 in Figure E.5).

**a supprimé:** Decision

**a supprimé:**

**a supprimé:** Technical Requirements for the Connection of Generating Stations to the Hydro-Québec Transmission System

### E.5.6 Open-loop pulse response

During open-loop pulse response testing, the stabilizer must be disabled without reducing the voltage regulator gain.

### E.5.7 Voltage regulator gain reduction

A single dry contact is needed to reduce the gain of the generator excitation system voltage regulator (logical state Gain reduction according to reference 12 in Figure E.5). The four conditions which require a reduction of the voltage regulator gain – i.e. the disabling of the stabilizer (see section E.5.1), the detection of a stabilizer fault (see section E.5.1), the detection of a generator mechanical fault (see section E.5.3) and particular conditions of partial load rejection (see section E.5.2) – must be grouped using a logic “OR” function, as shown in Figure E.5.

## E.6 Functional testing of stabilizer

The stabilizer must be subjected to validation and performance tests (see chapter 10) allowing complete verification of all the characteristics and performances of the stabilizer and the excitation system.

For this purpose, the stabilizer must include an internal function that allows pulse response testing of the stabilizer. This function allows to verify the functioning of the system which includes the stabilizer, the excitation system and the generator synchronized to the *Transmission System*, and this with the settings specified by the *Transmission Provider*.

Pulse response testing may be performed with the stabilizer operating in open-loop or closed-loop mode. Open-loop testing must trigger the disabling of the stabilizer without any reduction of the voltage regulator gain. The internal pulse signal (VSTEST) is injected with the stabilization signal (VS) to give the output signal of the stabilizer (VSS) (see figure 1).

#### Internal signals:

- The output of the pulse response function is the signal VSTEST in p.u.
- Open-loop pulse response testing must trigger the disabling of the stabilizer without any reduction of the voltage regulator gain.

#### Internal parameters:

- Pulse duration must be supplied as a pulse response test parameter. It must be adjustable from 0 to 1 second.
- Pulse amplitude must be supplied as a pulse response test parameter. It must be adjustable from 0 to +/- 0.10 p.u.

**a supprimé:** Decision

**a supprimé:**

**a supprimé:** Technical Requirements for the Connection of Generating Stations to the Hydro-Québec Transmission System

## Appendix F Requirements regarding verification and validation of power producer models and facilities

### Purpose and scope

This appendix defines and specifies technical requirements for verifying power producer *facilities* pursuant to section 10.2. It covers the validation and performance testing required to demonstrate that *generating stations* meet *Transmission Provider* requirements. It is divided in two sections, based on the type of generating equipment:

- 1) Conventional generation: hydraulic or thermal generation by means of *synchronous* or *asynchronous generators* with no converter
- 2) [Variable](#) generation: [generating stations using SERMOs](#)

**a supprimé:** Wind generation

Validation and performance testing is essential for the *Transmission Provider* to characterize the dynamic performance of generating equipment and to develop simulation models for dynamic simulation studies. The accuracy of models has a major impact on the estimation of capital spending for transmission, on the evaluation of transmission capacity, and ultimately on the development of operating strategies for the system and generating equipment. Accurate simulation models are also essential to determine what settings ensure optimal performances for both the equipment and the behavior of the system.

This appendix specifies the content of required initial and periodic verifications:

- Initial verifications:  
During startup of a new *generating station* or following a substantial change of an existing *generating station*, the power producer must verify that its *facilities* meet *Transmission Provider* requirements and achieve the required levels of performance.
- Periodic verifications:  
At intervals set by the *Transmission Provider*, the power producer must verify that its *facilities* have maintained their characteristics and their levels of performance.

### F.1 Conventional generation

This first section covers conventional equipment, such as *synchronous* or *asynchronous generators* driven by hydraulic or thermal turbines. Such technology is considered mature, and is thoroughly covered in the literature and guides. The power producer must verify and validate items as required by the *Transmission Provider*, and produce a report in accordance with the standards and methods described below.

**a supprimé:** Decision

**a supprimé:**

[Technical Requirements for the Connection of Generating Stations to the Hydro-Québec Transmission System](#)

Testing requirements aimed at validating the characteristics and dynamic performance of excitation systems, stabilizers and speed governors are based on NERC reliability standards, i.e., MOD 026-1 *Verification of Models and Data for Generator Excitation Control System or Plant Volt/Var Control Functions*<sup>24</sup> for excitation systems, and MOD-027-1 *Verification of Models and Data for Turbine/Governor and Load Control or Active Power/Frequency Control Functions*<sup>25</sup> for speed governors verification. Similarly, to validate the maximum [active](#) and reactive power capability of generating equipment, the *Transmission Provider* relies on requirements set in MOD-025-2 *Verification and Data Reporting of Generator Real and Reactive Power Capability and Synchronous Condenser Reactive Power Capability*<sup>26</sup>.

This section covers initial and periodic verifications of power producer *facilities*, and the various reports and documents to be delivered.

### F.1.1 Validation of *synchronous* and *asynchronous* generator models and parameter

The *synchronous* and *asynchronous* generator models and parameters requested by the *Transmission Provider* in Appendix A are essential to properly simulate the *Transmission System* behavior and ensure its transmission capacity.

#### Initial verifications:

- The power producer must validate, through testing, the parameters and models provided to the *Transmission Provider* for the purpose of conducting its studies.
- The method used to validate parameters is subject to the *Transmission Provider's* approval. For *synchronous generators*, validation method may rely on IEEE Guide 115 – *Test Procedures for Synchronous Machines*<sup>29</sup>. For *asynchronous generators*, the recommended reference is IEEE Standard 112 – *Test Procedure for Polyphase Induction Motors and Generators*<sup>30</sup>, but other standards may be considered on a case-by-case basis.
- Parameter validation is a type test (i.e., it is performed on one *generating unit* of each electrical design at the *generating station*), except for open-circuit characteristics (up to 1.2 p.u. of stator voltage) and short-circuit characteristics, which must be determined by testing each *generating station generating unit*.

#### Periodic verifications:

- No periodic verification is requested.

### F.1.2 Validation of voltage regulation system models and parameters

Voltage regulation system testing validates parameters and models used in dynamic simulation studies and settings tuning studies performed by the *Transmission Provider*. Tuning of settings has a major impact on both power system behavior and on the security of power producer and *Transmission Provider* equipment.

24 Reference provided for explanatory and information purposes only.

25 See note 24.

26 See note 24.

29 See note 24.

30 See note 24.

**a supprimé:** Technical Requirements for the Connection of Generating Stations to the Hydro-Québec Transmission System

**a supprimé:** real

**a supprimé:** , and on criteria set in NPCC Directory #9 – Verification of Generator Gross and Net Real Power Capability<sup>27</sup> and Directory #10 – Verification of Generator Gross and Net Reactive Power Capability<sup>28</sup>.

**a supprimé:** only

**a supprimé:** ve

**a supprimé:** Decision

**a supprimé:**



**a supprimé:** Technical Requirements for the Connection of Generating Stations to the Hydro-Québec Transmission System

**Initial verifications:**

- Applicable to all voltage regulation systems
- The power producer must demonstrate that *Transmission Provider* requirements described in section 6.4 are met.
- The power producer must update voltage regulator and excitation system models (p.u./p.u.) and block diagrams submitted to *Transmission Provider* to allow it to conduct its studies. The power producer must also apply settings given by *Transmission Provider*.
- Simulation models must faithfully represent the dynamic response of *generating units* during voltage and frequency variations [in accordance with the values](#) given in tables 2, 3 and 4 of sections 6.3.1 to 6.3.3. Tests are required to characterize all regulation system functions: automatic voltage regulator, underexcitation limiter, overexcitation limiter, V/Hz limiter, reactive current compensation, stabilizer, bridge firing circuits, sensors, etc.
- Validation method is subject to the *Transmission Provider's* approval, IEEE Guide 421.2 *Guide for Identification, Testing, and Evaluation of the Dynamic Performance of Excitation Control Systems*<sup>31</sup> being a recognized reference on validation parameters for voltage regulation systems.
- At least the following tests must be performed: with *generating unit* not synchronized, voltage set point step response; with *generating unit* synchronized, voltage set point step responses to validate excitation system gain with and without stabilizer, step responses to verify positive and negative ceilings of excitation system and immediate response of excitation system, step responses with and without stabilizer to validate overexcitation, underexcitation [and stator current limiters](#), and short-duration (voltage pulse) step responses with stabilizer, [and variation of the generating unit speed to verify the V/Hz limiter](#).
- Tests above are type tests performed on one *generating unit* of each electrical design found at the *generating station*, except for short-duration step responses with stabilizer, which must be performed by testing each *generating station generating unit*.
- The power producer must show that the model is adequate by demonstrating that a numerical simulation gives results closely matching test results.
- Measurement points: for each test, it is necessary to record at least the stator three-phase voltages and currents, the field voltage and current, and the stabilizer output signal. The power producer must ensure that excitation system has analog or digital inputs needed to run required tests (e.g., performing step responses). Excitation system must have analog inputs and outputs needed to determine and characterize transfer functions of different block diagrams. The power producer must ensure at design stage that measurement points will be readily accessible.

**a supprimé:** in the ranges

**a supprimé:** and

**Periodic verifications:**

Periodic verifications to be performed every [ten](#) years: at least, short-duration step responses with stabilizer must be performed for all *generating station generating units* and results must be similar to those obtained during initial verification of *generating units*. If periodic test results are not similar, the power producer must take necessary corrective action.

**a supprimé:** six

31 Reference provided for explanatory and information [only](#).

**a supprimé:** Decision

**a supprimé:**

**a supprimé:** Technical Requirements for the Connection of Generating Stations to the Hydro-Québec Transmission System

### F.1.3 Validation of speed governor models and parameters

Speed governor testing validates parameters and models used in dynamic simulation studies and settings tuning studies performed by the *Transmission Provider*. Tuning of settings has a major impact on both system behavior and on the security of power producer and *Transmission Provider* equipment. *Generating unit* speed regulation dictates both the system frequency behavior and its stability. It also has a direct impact on power quality.

#### Initial verifications:

- Applicable to all speed governors
- The power producer must demonstrate that its *facilities* meet *Transmission Provider* requirements described in section 6.4.
- The power producer must update speed governor models and block diagrams previously submitted to the *Transmission Provider* to allow it to conduct its studies. The power producer must also apply settings given by the *Transmission Provider*.
- Simulation models must faithfully represent the dynamic response of *generating units* during frequency variations in [accordance with the values](#) given in [Table 4](#) of section 6.3.3. Tests are needed to characterize all functions of speed governor system.
- The method used to validate speed governor system is subject to the *Transmission Provider's* approval. For hydraulic *generating stations*, the recommended reference is international standard IEC 60308 *Hydraulic turbines – Testing of control systems*<sup>32</sup>. For gas and steam turbines, CIGRE Technical Brochure 238 *Modeling of Gas Turbines and Steam Turbines in Combined Cycle Power Plants*<sup>33</sup> is the recommended reference.
- Validation of parameters and models described below is performed through type tests on one *generating unit* of each electrical design found at the *generating station*. The power producer must identify transfer functions for speed governor mechanical components and sensors on a block-by-block basis. Tests must be run for various operating points within operating range of *generating units*. The power producer must also perform tests to validate *generating unit* inertia constant H. After identifying blocks, frequency step responses must be performed to demonstrate that overall model is adequate. At least the following frequency step responses must be performed: with *generating unit* not synchronized, one frequency step response; with *generating unit* synchronized, positive frequency step responses at 10%, 50% and 90% of rated capacity, and one negative frequency step response at 90% of rated capacity.
- The positive frequency step response at 90% of rated capacity must be performed on all *generating station generating units*. Results will serve as a benchmark (signature) for periodic verifications.
- The power producer must demonstrate model adequacy by demonstrating that a numerical simulation gives results closely matching test results.

**a supprimé:** the ranges

**a supprimé:** Table 4

<sup>32</sup> Reference provided for explanatory and information purposes [only](#).

<sup>33</sup> See note 32.

**a supprimé:** Decision

**a supprimé:**

[Technical Requirements for the Connection of Generating Stations to the Hydro-Québec Transmission System](#)

- Measurement points: for each test, it is necessary to record at least frequency, [active](#) power, and outputs of main blocks of speed governor. The power producer must ensure that speed governor system has analog or digital inputs required to run required tests (e.g., measuring step responses). Speed governor system must have analog inputs and outputs required to determine and characterize different block diagrams transfer functions. The power producer must ensure, at design stage, that measurement points will be readily accessible.

**Periodic verifications:**

Periodic verifications to be performed every [ten](#) years: the power producer must at least perform positive frequency step response at 90% of rated capacity for every *generating station generating unit*; results must be similar to those obtained during initial verifications of *generating units*. If periodic test results are not similar, the power producer must take necessary corrective action.

**F.1.4 Harmonics**

**Initial verifications:**

If required by the *Transmission Provider*, the power producer must run validation tests in accordance with requirements described in section 7.6.3. Such tests must be run on each *generating unit* before it is synchronized. If results are unsatisfactory, *generating unit* cannot be synchronized to the system unless expressly authorized by the *Transmission Provider*.

**Periodic verifications:**

No periodic verification is requested.

**F.1.5 Maximum capacity: [active and reactive power](#)**

The purpose of this validation testing is to determine the maximum [active and reactive power](#) of a *generating station* under various operating conditions. The first step is to evaluate maximum [active and reactive power](#) of the *generating station* by performing a station test for all *generating units* while remaining within the system operating voltage limits and meeting any system thermal constraints. The second step is to evaluate a *generating station's* maximum [active and reactive power](#) in order to confirm the rated power factor of each generator. This test measures the ability of generators to withstand *Transmission System* voltage during a contingency such as the *tripping* of one or several transmission lines. This evaluation is performed by applying a unit test on each generator individually up to its maximum capacity without causing a *generating station* or system operating constraint.

**a supprimé:** Technical Requirements for the Connection of Generating Stations to the Hydro-Québec Transmission System

**a supprimé:** real

**a supprimé:** six

**a supprimé:** 7.8

**a supprimé:** real and reactive power

**a supprimé:** real and reactive power

**a supprimé:** real and reactive power

**a supprimé:** real and reactive power

**a supprimé:** Decision

**a supprimé:**

**Initial [and periodic](#) verifications:**

- Initial [and periodic](#) verifications consist in running both the station tests and the unit tests (i.e., those run on each *generating unit*) described in Québec balancing authority area procedure IQ\_P-001 [Verification of Maximum Real and Reactive Power Capabilities of MTS Generating Facilities and Synchronous Compensators](#)<sup>34</sup>

**F.1.6 Transformer data**

- When the power producer supplies *generating unit* step-up transformers, it must submit to the *Transmission Provider* results of factory type and routine tests performed on all such transformers. It must also submit to the *Transmission Provider*, where appropriate, a description of any voltage regulation performed by on-load tap changers, including regulation modes and associated block diagrams.

**F.1.7 Instrumentation**

Instrumentation used by the power producer to perform validation testing must have the following minimal features:

- Digital instruments to facilitate matching test results to numerical simulation results
- Accuracy: 16 bits
- Minimum of 16 channels
- Anti-aliasing filters adjustable to sampling rate or based on sigma-delta technique
- Sampling rate and recording time: adjustable depending on test requirements. For example, a voltage regulator step response test requires sampling at a rate of 10 kHz or higher for about 30 s, while a step response validation test on an overexcitation limiter may require recording for several minutes, but at a lower sampling rate (2 kHz).

**F.1.8 Deliverables**

While it is recognized that certain validation tests may be run in the factory, most testing will be conducted on site, some tests with the *generating unit* shut down, others with it running and either synchronized or not.

- Documents and test reports must be prepared and signed by an engineer.
- Six months prior to very first (factory or on-site) test, the power producer must submit to the *Transmission Provider* a comprehensive test program describing regulation systems and test methods that will be used to obtain parameters to be verified, test location (factory or on site) and preliminary schedule. Test program will be reviewed for approval by the *Transmission Provider*.
- Three months before any testing begins, the power producer must submit to the *Transmission Provider* a detailed procedure covering the following points: list of parameters verified by testing, validation method, test conditions (“on grid” or “off grid” and initial conditions), all procedure steps, variables recorded, characteristics of measuring chain and test schedule.

**a supprimé:** Technical Requirements for the Connection of Generating Stations to the Hydro-Québec Transmission System

**a supprimé:** on

**a supprimé:** of 50 MVA or Higher Capacity

**a supprimé: Periodic verifications:¶**  
Items to be verified periodically are described in procedure IQ-P-001.¶  
For *generating stations* of 50 MVA or higher capacity located in Québec, a station test must be performed once every three years, during the winter.¶  
Unit tests may be performed at any time, but no less than once every six years.¶

34 Reference provided for explanatory and information purposes [only](#).

**a supprimé:** Decision

**a supprimé:**

[Technical Requirements for the Connection of Generating Stations to the Hydro-Québec Transmission System](#)

- The *Transmission Provider* reserves right to witness certain tests or verifications performed by the power producer or its suppliers. The power producer must therefore promptly notify the *Transmission Provider* of any change in schedule.
- Test reports must contain a description of systems verified and models validated (for voltage regulation and speed governing), tables of parameters provided by the power producer to the *Transmission Provider* for *interconnection study* and parameters obtained during validation testing, and figures comparing test results with numerical simulation results (for voltage regulation and speed governing). Reports must be submitted to the *Transmission Provider* for comments. The *Transmission Provider* has one month to provide comments. Submittal of final version of test reports by the power producer is one prerequisite for final acceptance of *facilities* by the *Transmission Provider*.
- The power producer must also submit raw test data (recorder data) should the *Transmission Provider* so require.

a supprimé: Technical Requirements for the Connection of Generating Stations to the Hydro-Québec Transmission System

## F.2 Variable generation

This second section covers [generation from generating stations using SERMOs](#).

The power producer is responsible for conducting the tests, the purpose of which is to verify compliance with requirements and validate simulation models. It is the *Transmission Provider*, however, who supplies and installs the instrumentation required for testing and analyzes test results unless the *Transmission Provider* and the power producer agree otherwise.

Performing such tests is one of the prerequisites for final *Transmission Provider* acceptance of *generating station* connection.

a supprimé: Wind

a supprimé: wind

a supprimé: SERMO

### F.2.1 Initial verifications:

Initial verifications are done both by testing and by using a monitoring system.

Tests must be run by the power producer but the description of the tests is provided by the *Transmission Provider*. Certain verifications are also made throughout the period of operation of the *generating station*, [for example of power quality](#), using a monitoring system installed by the *Transmission Provider*.

Tests are intended to verify.

- Primary voltage regulation
- Undervoltage response and LVRT
- Frequency control
- Secondary voltage regulation
- Power factor
- Maximum ramp rates
- [Harmonic impedance of inverters and the generating station](#)

a déplacé vers le bas [4]: Test methods and description specific to wind *generating stations* are presented in the document *General Validation Test Program for Wind Power Plants Connected to the Hydro-Québec Transmission System*<sup>36</sup>.

[Test methods and description specific to wind \*generating stations\* are presented in the document \*General Validation Test Program for Wind Power Plants Connected to the Hydro-Québec Transmission System\*<sup>36</sup>](#)

a déplacé (et inséré) [4]

a supprimé: ve

a supprimé: Decision

a supprimé:

<sup>36</sup> Reference provided for explanatory and information purposes only.

[Technical Requirements for the Connection of Generating Stations to the Hydro-Québec Transmission System](#)

**a supprimé:** Technical Requirements for the Connection of Generating Stations to the Hydro-Québec Transmission System

### F.2.2 Periodic verifications:

The *Transmission Provider* will make specific requests for periodic testing (every six years). The power producer must allow such testing by providing appropriate test conditions and by assisting the *Transmission Provider*, free of charge, in conducting the tests.

**a supprimé:** There are no specific tests for power quality in the general test program. Power quality is only validated during *generating station* operation.

**a supprimé:** Decision

**a supprimé:**

I hereby certify that the track changes made to the English document (to be filed on February 28, 2022) are a complete and accurate translation of the changes made to the French document (filed on November 30, 2021).

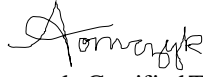

Anna Tomczyk, Certified Translator  
OTTIAQ, Member No. 7979

Signed in Montréal, Québec, on February 24, 2022